

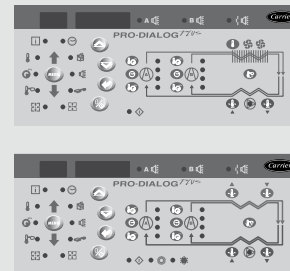

United Technologies

PRO-DIALOG

INSTALLATION, OPERATION AND MAINTENANCE INSTRUCTIONS

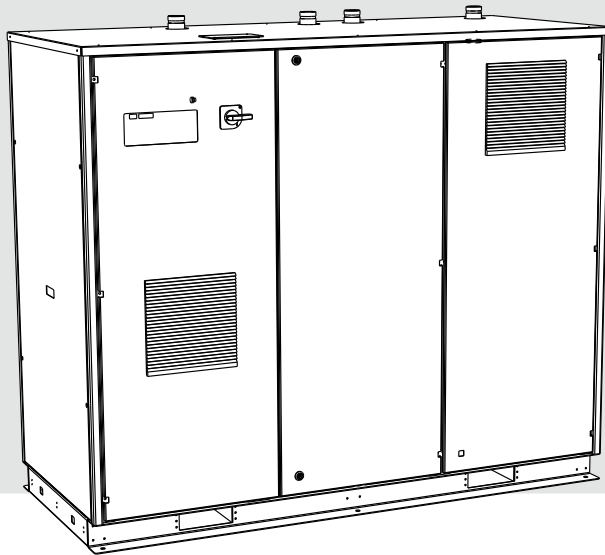

Water-Cooled/Condenserless Liquid Chillers
with Integrated Hydronic Modules

30RW/RWA

Nominal cooling capacity 110-310 kW / 50 Hz



CONTENTS

1 - INTRODUCTION	4
1.1 - Installation safety considerations	4
1.2 - Equipment and components under pressure.....	5
1.3 - Maintenance safety considerations.....	5
1.4 - Repair safety considerations	6
2 - PRELIMINARY CHECKS	7
2.1 - Check equipment received.....	7
2.2 - Moving and siting the unit.....	7
3 - DIMENSIONS, CLEARANCES, WEIGHT DISTRIBUTION	8
3.1 - 30RW/30RWA 110-150 - unit with or without hydronic module	8
3.2 - 30RW/30RWA 160-300 - unit without hydronic module (standard).....	9
3.3 - 30RW/30RWA 160-300 - unit with hydronic module (option)	9
4 - PHYSICAL AND ELECTRICAL DATA.....	10
4.1 - Physical data	10
4.2 - Electrical data.....	11
4.3 - Electrical data, optional hydronic module	12
4.4 - Compressor usage and electrical data table.....	14
5 - APPLICATION DATA	14
5.1 - Operating limits 30RW/RWA	14
5.2 - Operating range 30RW	14
5.3 - Operating range 30RWA	15
5.4 - Minimum chilled water flow	15
5.5 - Maximum chilled water flow.....	15
5.6 - Variable flow evaporator	15
5.7 - Evaporator flow rate	15
5.8 - Condenser water flow rate (l/s)	15
5.9 - Minimum chilled water loop volume	16
5.10 - Maximum water loop volume (evaporator and condenser side).....	16
5.11 - Minimum hot water loop volume	16
5.12 - Evaporator and condenser pressure drop curves	17
6 - ELECTRICAL CONNECTION.....	18
6.1 - Electrical connections 30RW/30RWA units.....	18
6.2 - Power supply.....	19
6.3 - Voltage phase imbalance (%).....	19
6.4 - Recommended wire sections.....	19
7 - WATER CONNECTIONS.....	20
7.1 - Operating precautions	20
7.2 - Water connections.....	21
7.3 - Frost protection	21
7.4 - Evaporator flow switch and chilled water pump interlock (units without hydronic module)	21
8 - REFRIGERANT LINE CONNECTIONS (30RWA)	23
8.1 - Recommendations for the installation of liquid chillers with remote condensers	23
8.2 - General	23
8.3 - Use of pipe sizing diagrams.....	23
8.4 - Discharge pipe sizing	24
8.5 - Liquid pipe sizing	24
9 - NOMINAL EVAPORATOR WATER FLOW CONTROL.....	26
9.1 - Water flow control procedure	26
9.2 - Evaporator pump flow/pressure curve.....	27
9.3 - Available static system pressure (evaporator side)	27
10 - CONDENSER WATER FLOW RATE	28
10.1 - Condenser pump flow/pressure curve.....	28
10.2 - Available static system pressure (condenser side).....	28

11 - 30RW UNIT OPERATION WITH A DRYCOOLER.....	29
11.1 - Operating principle	29
11.2 - Auxiliary electronic analogue input and output and discrete output board (AUX1) for control of the drycooler..	29
11.3 - Configuration of the number of fan stages and the automatic changeover of the fan stages.....	29
11.4 - Fan stage assignment.....	29
11.5 - 30RW units without evaporator and condenser pump, three-way valve configuration for low outside temperature application	30
11.6 - Drycooler installation	30
12 - 30RWA UNIT OPERATION WITH REMOTE AIR-COOLED CONDENSER.....	30
12.1 - Operating principle	30
12.2 - Master fan	30
12.3 - Dual-circuit condenser with separate ventilation and interlaced ventilation.....	30
12.4 - Auxiliary electronic analogue input and output and discrete output board (AUX1) for control of the air-cooled remote condenser.....	30
12.5 - Configuration of the number of fan stages and fan type based on the air-cooled condenser model used in the installation	30
12.6 - Possible fan arrangements based on the air-cooled condenser type used in the installation	31
13 - START-UP.....	33
13.1 - Preliminary checks	33
13.2 - Actual start-up	33
13.3 - Operation of two units in master/slave mode	33
14 - MAJOR SYSTEM COMPONENTS AND OPERATION DATA	34
14.1 - Compressors.....	34
14.2 - Lubricant	34
14.3 - Evaporators and condensers	34
14.4 - Thermostatic expansion device	35
14.5 - Refrigerant	35
14.6 - High-pressure switch.....	35
14.7 - High and low-pressure side safety valves	35
14.8 - Moisture indicator	35
14.9 - Filter drier in the refrigerant circuit	35
14.10 - Fixed-speed cold water loop pump (evaporator side)	35
14.11 - Variable-speed hot water loop pump (condenser side)	36
14.12 - Evaporator and condenser pump suction filter.....	36
15 - MAINTENANCE.....	36
15.1 - Soldering and welding.....	36
15.2 - General unit maintenance	37
15.3 - Refrigerant charge.....	37
15.4 - Refrigerant guidelines	37
15.5 - Leak detection	38
15.6 - Evacuation	38
15.7 - Recharging liquid refrigerant.....	38
15.8 - Characteristics of R-407C.....	38
15.9 - Electrical maintenance	38
15.10 - Compressors.....	39
15.11 - Evaporator and condenser maintenance	39
15.12 - Corrosion check	39
16 - AQUASNAP MAINTENANCE PROGRAM	40
16.1 - Maintenance schedule.....	40
16.2 - Description of the maintenance operations	40
17 - START-UP CKECKLIST FOR 30RW/RWA LIQUID CHILLERS (USE FOR JOB FILE).....	41
Preliminary information	41
Preliminary equipment check	41

The cover photograph is for illustrative purposes only and is not part of any offer for sale or contract.

1 - INTRODUCTION

Prior to the initial start-up of the 30RW/30RWA units, the people involved in the on-site installation, start-up, operation and maintenance of this unit should be thoroughly familiar with these instructions and the specific project data for the installation site.

The 30RW/30RWA liquid chillers are designed to provide a very high level of safety during installation, start-up, operation and maintenance. They will provide safe and reliable service when operated within their application range.

This manual provides the necessary information to familiarize yourself with the control system before performing start-up procedures. The procedures in this manual are arranged in the sequence required for machine installation, start-up, operation and maintenance.

Be sure you understand and follow the procedures and safety precautions contained in the instructions supplied with the machine, as well as those listed in this guide.

To find out, if these products comply with European directives (machine safety, low voltage, electromagnetic compatibility, equipment under pressure etc.) check the declarations of conformity for these products.

1.1 - Installation safety considerations

After the unit has been received, when it is ready to be installed or reinstalled, and before it is started up, it must be inspected for damage. Check that the refrigerant circuit(s) is (are) intact, especially that no components or pipes have shifted (e.g. following a shock). If in doubt, carry out a leak tightness check and verify with the manufacturer that the circuit integrity has not been impaired. If damage is detected upon receipt, immediately file a claim with the shipping company.

Do not remove the skid or the packaging until the unit is in its final position. These units can be moved with a fork lift truck, as long as the forks are positioned in the right place and direction on the unit.

The units can also be lifted with slings, using only the designated lifting points marked on the unit.

These units are not designed to be lifted from above. Use slings with the correct capacity, and always follow the lifting instructions on the certified drawings supplied with the unit.

Safety is only guaranteed, if these instructions are carefully followed. If this is not the case, there is a risk of material deterioration and injuries to personnel.

DO NOT COVER ANY PROTECTION DEVICES.

This applies to fuse plugs and safety valves (if used) in the refrigerant or heat transfer medium circuits. Check if the original protection plugs are still present at the valve outlets. These plugs are generally made of plastic and should not be used. If they are still present, please remove them. Install devices at the valve outlets or drain piping that prevent the penetration of foreign bodies (dust, building debris, etc.) and atmospheric agents (water can form rust or ice). These devices, as well as the drain piping, must not impair operation and not lead to a pressure drop that is higher than 10% of the control pressure.

Classification and control

In accordance with the Pressure Equipment Directive and national usage monitoring regulations in the European Union the protection devices for these machines are classified as follows:

	Safety accessory*	Damage limitation accessory** in case of an external fire
Refrigerant side		
High-pressure switch	x	
External relief valve***		x
Rupture disk		x
Fuse plug		x
Heat transfer fluid side		
External relief valve****	x	x

* Classified for protection in normal service situations.

** Classified for protection in abnormal service situations.

*** The instantaneous over-pressure limited to 10% of the operating pressure does not apply to this abnormal service situation. The control pressure can be higher than the service pressure. In this case either the design temperature or the high-pressure switch ensures that the service pressure is not exceeded in normal service situations.

**** The classification of these safety valves must be made by the personnel that completes the whole hydronic installation.

Do not remove these valves and fuses, even if the fire risk is under control for a particular installation. There is no guarantee that the accessories are re-installed if the installation is changed or for transport with a gas charge.

All factory-installed safety valves are lead-sealed to prevent any calibration change. If the safety valves are installed on a reversing valve (change-over), this is equipped with a safety valve on each of the two outlets. Only one of the two safety valves is in operation, the other one is isolated. Never leave the reversing valve in the intermediate position, i.e. with both ways open (locate the control element in the stop position). If a safety stop is removed for checking or replacement please ensure that there is always an active safety stop on each of the reversing valves installed in the unit.

The external safety valves must always be connected to drain pipes for units installed in a closed room. Refer to the installation regulations, for example those of European standard EN 378 and EN 13136.

These pipes must be installed in a way that ensures that people and property are not exposed to refrigerant leaks. As the fluids can be diffused in the air, ensure that the outlet is far away from any building air intake, or that they are discharged in a quantity that is appropriate for a suitably absorbing environment.

Periodic check of the safety valves: See paragraph 1.3 - "Maintenance safety considerations?"

Provide a drain in the drain pipe, close to each safety valve, to avoid an accumulation of condensate or rain water.

All precautions concerning handling of refrigerant must be observed in accordance with local regulations.

Ensure good ventilation, as accumulation of refrigerant in an enclosed space can displace oxygen and cause asphyxiation or explosions.

Inhalation of high concentrations of vapour is harmful and may cause heart irregularities, unconsciousness, or death. Vapour is heavier than air and reduces the amount of oxygen available for breathing. These products cause eye and skin irritation. Decomposition products are hazardous.

1.2 - Equipment and components under pressure

These products incorporate equipment or components under pressure, manufactured by Carrier or other manufacturers. We recommend that you consult your appropriate national trade association or the owner of the equipment or components under pressure (declaration, re-qualification, retesting, etc.). The characteristics of this equipment/these components are given on the nameplate or in the required documentation, supplied with the products.

Do not introduce significant static or dynamic pressure with regard to the operating pressures used during operation or for tests in the refrigerant circuit or in the heat exchange circuits, specifically by limiting the glycol cooler elevation.

1.3 - Maintenance safety considerations

Engineers working on the electric or refrigeration components must be authorized, trained and fully qualified to do so.

All refrigerant circuit repairs must be carried out by a trained person, fully qualified to work on these units. He must have been trained and be familiar with the equipment and the installation. All welding operations must be carried out by qualified specialists.

Any manipulation (opening or closing) of a shut-off valve must be carried out by a qualified and authorised engineer. These procedures must be carried out with the unit shut down.

ATTENTION: *The liquid line valve must always be fully open, when there is refrigerant in the circuit (this valve is situated on the liquid line before the filter drier box.*

Any intervention on the refrigerant circuit, including changing of drier blocks, is only permitted after the complete removal of the refrigerant charge. For these units transfer of the refrigerant charge from the high or low-pressure side is not possible, nor permitted.

During any handling, maintenance and service operations the engineers working on the unit must be equipped with safety gloves, glasses, shoes and protective clothing.

Never work on a unit that is still energised.

Never work on any of the electrical components, until the general power supply to the unit has been cut using the disconnect switch in the control box.

If any maintenance operations are carried out on the unit, lock the power supply circuit in the open position ahead of the machine.

If the work is interrupted, always ensure that all circuits are still deenergized before resuming the work.

ATTENTION: *Even if the compressor motors have been switched off, the power circuit remains energized, unless the unit or circuit disconnect switch is open. Refer to the wiring diagram for further details.*

Attach appropriate safety labels.

Operating checks:

IMPORTANT INFORMATION REGARDING THE REFRIGERANT USED:

- *This product contains fluorinated greenhouse gas covered by the Kyoto protocol.
Refrigerant type: R-407C
Global Warming Potential (GWP): 1774*

Periodic inspections for refrigerant leaks may be required depending on European or local legislation. Please contact your local dealer for more information.

- *During the life-time of the system, inspection and tests must be carried out in accordance with national regulations.*

The information on operating inspections given in annex C of standard EN378-2 can be used if no similar criteria exist in the national regulations.

Protection device checks:

- *If no national regulations exist, check the protection devices on site in accordance with standard EN378: once a year for the high-pressure switches, every five years for external safety valves.*
- *Check manual "30RW/RWA Pro-Dialog Plus control" for a detailed explanation of the high-pressure switch test method.*

At least once a year thoroughly inspect the protection devices (valves, pressure switches). If the machine operates in a corrosive environment, inspect the protection devices more frequently.

Regularly carry out leak tests and immediately repair any leaks.

1.4 - Repair safety considerations

All installation parts must be maintained by the personnel in charge, in order to avoid material deterioration and injuries to people. Faults and leaks must be repaired immediately. The authorized technician must have the responsibility to repair the fault immediately. After each repair of the unit, check the operation of the protection devices and create a report of the parameter operation at 100%.

Comply with the regulations and recommendations in unit and HVAC installation safety standards, such as: EN 378, ISO 5149, etc.

If a leak occurs or if the refrigerant becomes polluted (e.g. by a short circuit in a motor) remove the complete charge using a recovery unit and store the refrigerant in mobile containers.

Repair the leak detected and recharge the circuit with the total R-407C charge, as indicated on the unit name plate. Do not top up the refrigerant charge. Only charge liquid refrigerant R-407C at the liquid line.

Ensure that you are using the correct refrigerant type before recharging the unit.

Charging any refrigerant other than the original charge type (R-407C) will impair machine operation and can even destroy the compressors. The compressors operating with this refrigerant type are lubricated with a synthetic polyol-ester oil.

Never use air or a gas containing oxygen during leak tests to purge lines or to pressurise a machine. Pressurised air mixtures or gases containing oxygen can be the cause of an explosion. Oxygen reacts violently with oil and grease.

Only use dry nitrogen for leak tests, possibly with an appropriate tracer gas.

If the recommendations above are not observed, this can have serious or even fatal consequences and damage the installation.

Never exceed the specified maximum operating pressures. Verify the allowable maximum high- and low-side test pressures by checking the instructions in this manual and the pressures given on the unit name plate.

Do not unweld or flamecut the refrigerant lines or any refrigerant circuit component until all refrigerant (liquid and vapour) as well as the oil have been removed from chiller. Traces of vapour should be displaced with dry nitrogen. Refrigerant in contact with an open flame produces toxic gases.

The necessary protection equipment must be available, and appropriate fire extinguishers for the system and the refrigerant type used must be within easy reach.

Do not siphon refrigerant.

Avoid spilling liquid refrigerant on skin or splashing it into the eyes. Use safety goggles and safety gloves. Wash any spills from the skin with soap and water. If liquid refrigerant enters the eyes, immediately and abundantly flush the eyes with water and consult a doctor.

Never apply an open flame or live steam to a refrigerant container. Dangerous overpressure can result. If it is necessary to heat refrigerant, use only warm water.

During refrigerant removal and storage operations follow applicable regulations. These regulations, permitting conditioning and recovery of halogenated hydrocarbons under optimum quality conditions for the products and optimum safety conditions for people, property and the environment are described in standard NF E29-795.

Any refrigerant transfer and recovery operations must be carried out using a transfer unit. A 3/8" SAE connector on the manual liquid line valve is supplied with all units for connection to the transfer station. The units must never be modified to add refrigerant and oil charging, removal and purging devices. All these devices are provided with the units. Please refer to the certified dimensional drawings for the units.

Do not re-use disposable (non-returnable) cylinders or attempt to refill them. It is dangerous and illegal. When cylinders are empty, evacuate the remaining gas pressure, and move the cylinders to a place designated for their recovery. Do not incinerate.

Do not attempt to remove refrigerant circuit components or fittings, while the machine is under pressure or while it is running. Be sure pressure is at 0 kPa and that the unit has been shut down and de-energised before removing components or opening a circuit. If the refrigerant circuit is open to carry out a repair, all circuit openings must be plugged, if the repair takes longer than 30 minutes. This prevents humidity from contaminating the circuit, especially the oil. If the work is expected to take longer, charge the circuit with nitrogen.

Do not attempt to repair or recondition any safety devices when corrosion or build-up of foreign material (rust, dirt, scale, etc.) is found within the valve body or mechanism. If necessary, replace the device. Do not install safety valves in series or backwards.

ATTENTION: No part of the unit must be used as a walk-way, rack or support. The refrigerant lines can break under the weight and release refrigerant, causing personal injury.

Do not climb on a machine. Use a platform, or staging to work at higher levels.

Use mechanical lifting equipment (crane, hoist, winch, etc.) to lift or move heavy components. For lighter components, use lifting equipment when there is a risk of slipping or losing your balance.

Use only original replacement parts for any repair or component replacement. Consult the list of replacement parts that corresponds to the specification of the original equipment.

Do not drain water circuits containing industrial brines, without informing the technical service department at the installation site or a competent body first.

Close the entering and leaving water shutoff valves and purge the unit water circuit, before working on the components installed on the circuit (screen filter, pump, water flow switch, etc.).

Periodically inspect all valves, fittings and pipes of the refrigerant and hydronic circuits to ensure that they do not show any corrosion or any signs of leaks.

It is recommended to wear ear defenders, when working near the unit and the unit is in operation.

2 - PRELIMINARY CHECKS

2.1 - Check equipment received

- Inspect the unit for damage or missing parts. If damage is detected, or if shipment is incomplete, immediately file a claim with the shipping company.
- Compare the name plate data with the order. The name plate is attached in two places to the unit:
 - on one of the unit sides on the outside,
 - on the control box door on the inside.
- The unit name plate must include the following information:
 - Version number
 - Model number
 - CE marking
 - Serial number
 - Year of manufacture and test date
 - Refrigerant used and refrigerant class
 - Refrigerant charge per circuit
 - Containment fluid to be used
 - PS: Min./max. allowable pressure (high and low pressure side)
 - TS: Min./max. allowable temperature (high and low pressure side)
 - Pressure switch cut-out pressure
 - Unit leak test pressure
 - Voltage, frequency, number of phases
 - Maximum current drawn
 - Maximum power input
 - Unit net weight
- Confirm that all accessories ordered for on-site installation have been supplied, are complete and undamaged.
- Do not keep the 30RW/30RWA units outside where they are exposed to the weather, as the sensitive control mechanism and the electronic modules may be damaged.

The unit must be checked periodically during its whole operating life to ensure that no shocks (handling accessories, tools etc.) have damaged it. If necessary, the damaged parts must be repaired or replaced. See chapter “Maintenance”

The machine must be installed in a place that is not accessible to the public or protected against access by non-authorized persons.

2.2 - Moving and siting the unit

2.2.1 - Moving

See chapter 1.1 - “Installation safety considerations”

2.2.2 - Siting the unit

Always refer to the chapter “Dimensions and clearances” to confirm that there is adequate space for all connections and service operations. For the centre of gravity coordinates, the position of the unit mounting holes, and the weight distribution points, refer to the certified dimensional drawing supplied with the unit.

Typical applications of these units are in refrigeration systems, and they do not require earthquake resistance. Earthquake resistance has not been verified.

In case of extra-high units the machine environment must permit easy access for maintenance operations.

CAUTION: Only use slings at the designated lifting points which are marked on the unit.

Before siting the unit check that:

- the permitted loading at the site is adequate or that appropriate strengthening measures have been taken.
- the unit is installed level on an even surface (maximum tolerance is 1.5 mm in both axes).
- there is adequate space above the unit for air flow and to ensure access to the components.
- the number of support points is adequate and that they are in the right places.
- the location is not subject to flooding.

CAUTION: Before lifting the unit, check that all casing panels are securely fixed in place. Lift and set down the unit with great care. Tilting and jarring can damage the unit and impair unit operation.

If 30RW/RWA units are hoisted with rigging, it is necessary to protect the unit frame (side and rear panels and front doors) against accidental crushing while a unit is being moved. Use struts or lifting beams to spread the slings above the unit. Do not tilt a unit more than 15°. Always follow the instructions on the handling notice attached to the unit.

If a unit includes a hydronic module (options 116B, 116C, 270B, 270C), the hydronic module and pump piping must be installed in a way that does not submit it to any strain. The hydronic module pipes must be fitted so that the pump does not support the weight of the pipes.

Never push or lever on any of the enclosure panels (panels, uprights, front access doors) of the unit. Only the base of the unit frame is designed to withstand such stresses.

Checks before system start-up

Before the start-up of the refrigeration system, the complete installation, including the refrigeration system must be verified against the installation drawings, dimensional drawings, system piping and instrumentation diagrams and the wiring diagrams.

For these checks national regulations must be followed. If the national regulation does not specify any details, refer to standard EN 378-2 as follows:

External visual installation checks:

- Compare the complete installation with the refrigeration system and power circuit diagrams.
- Check that all components comply with the design specifications.
- Check that all protection documents and equipment provided by the manufacturer (dimensional drawings, P&ID, declarations etc.) to comply with the regulations are present.
- Verify that the environmental safety and protection and devices and arrangements provided by the manufacturer to comply with the regulations are in place.
- Verify that all documents for pressure containers, certificates, name plates, files, instruction manuals provided by the manufacturer to comply with the regulations are present.

- Verify the free passage of access and safety routes.
- Check that ventilation in the plant room is adequate.
- Check that refrigerant detectors are present.
- Verify the instructions and directives to prevent the deliberate removal of refrigerant gases that are harmful to the environment.
- Verify the installation of connections.
- Verify the supports and fixing elements (materials, routing and connection).
- Verify the quality of welds and other joints.
- Check the protection against mechanical damage.
- Check the protection against heat.
- Check the protection of moving parts.
- Verify the accessibility for maintenance or repair and to check the piping.
- Verify the status of the valves.
- Verify the quality of the thermal insulation and of the vapour barriers.



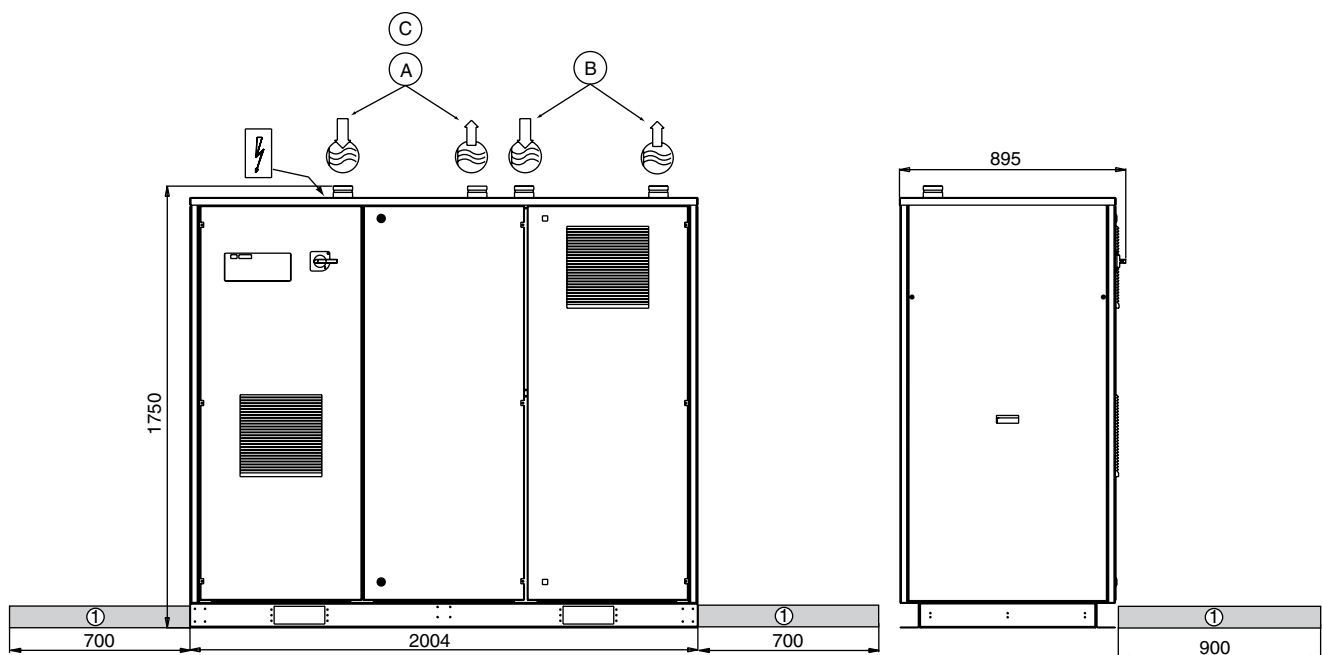

3 - DIMENSIONS, CLEARANCES, WEIGHT DISTRIBUTION

3.1 - 30RWA 110-150 - unit with or without hydronic module



Legend:

All dimensions are in mm.

-  Water inlet
-  Water outlet
- A Condenser (water inlet/outlet for 30RW units)
- B Evaporator
- C Refrigerant inlet/outlet (30RW only)
-  Clearances required for maintenance
-  Power supply

NOTE: Non-contractual drawings. Refer to the certified dimensional drawings.

For the positioning of the fixing points, weight distribution and centre of gravity coordinates, also refer to the certified drawings.

For 30RWA units without condenser, installed with a remote air-cooled condenser, the refrigerant inlet and outlet position correspond to the condenser water inlets and outlets. See C in the legend on the left.

3.2 - 30RW/30RWA 160-300 - unit without hydronic module (standard)

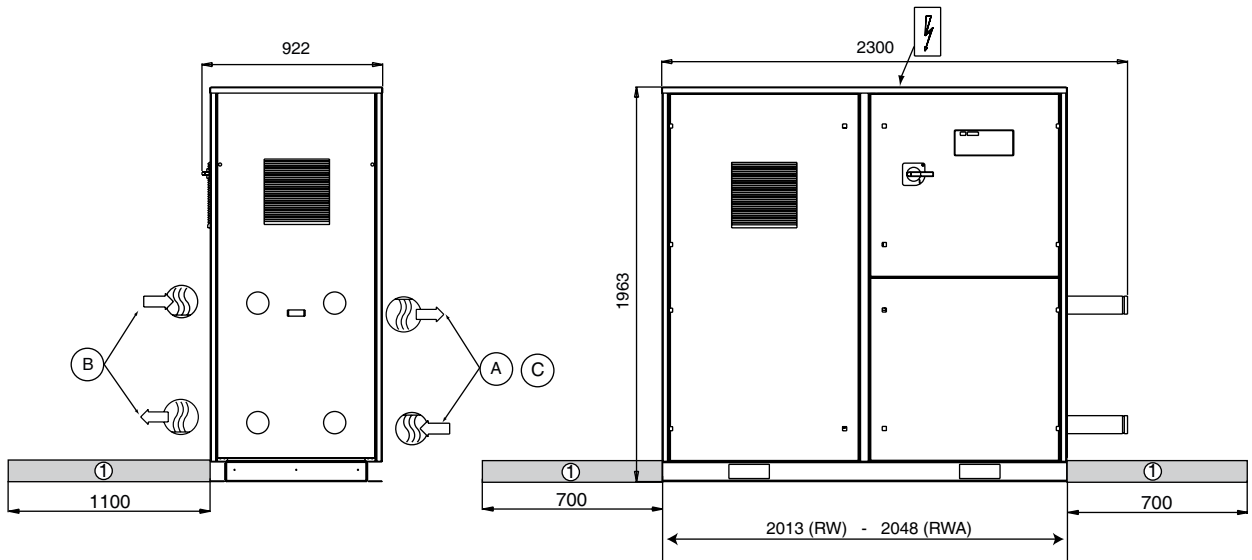

3.3 - 30RW/30RWA 160-300 - unit with hydronic module (option)

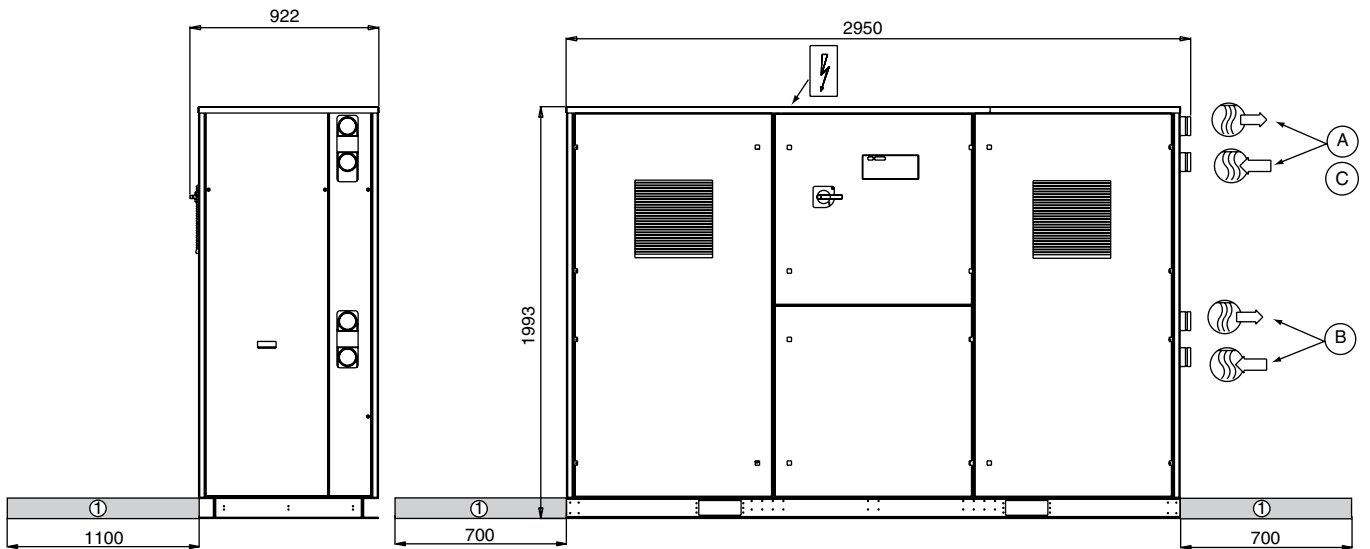

Legend:

All dimensions are in mm.



Water inlet



Water outlet

A Condenser (water inlet/outlet for 30RW units)

B Evaporator

C Refrigerant inlet/outlet (30RW only)

① Clearances required for maintenance



Power supply

NOTE: Non-contractual drawings. Refer to the certified dimensional drawings.

For the positioning of the fixing points, weight distribution and centre of gravity coordinates, also refer to the certified drawings.

For 30RWA units without condenser, installed with a remote air-cooled condenser, the refrigerant inlet and outlet position correspond to the condenser water inlets and outlets. See C in the legend on the left.

4 - PHYSICAL AND ELECTRICAL DATA

4.1 - Physical data

30RW/RWA		110	120	135	150	160	185	210	245	275	300
Nominal cooling capacity											
30RW*	kW	-	-	-	-	-	-	216	247	284	310
30RWA**	kW	102	117	134	143	148	170	198	226	264	291
Operating weight											
30RW weight without hydronic module	kg	-	-	-	-	-	-	1357	1471	1421	1491
30RWA weight without hydronic module	kg	777	840	849	859	953	1000	1318	1318	1361	1371
Extra weight											
Evaporator with single pump hydronic kit	kg	15	15	15	15	75	75	75	75	60	63
Condenser with single pump hydronic kit	kg	80	80	80	80	80	80	95	95	97	101
Evaporator with dual pump hydronic kit	kg	130	130	130	130	130	130	188	188	-	-
Condenser with dual pump hydronic kit	kg	140	140	140	140	140	140	198	198	-	-
Casing if hydronic option is used	kg	-	-	-	-	170	170	170	170	-	-
Refrigerant 30RW***											
		R-407C									
Circuit A	kg	-	-	-	-	-	-	19	19	24	24
Circuit B	kg	-	-	-	-	-	-	19	19	24	24
Compressors 30RW/30RWA											
		Hermetic scroll 48.3 r/s									
Circuit A		2	2	2	2	2	2	2	2	2	2
Circuit B		-	-	-	-	2	2	2	2	2	2
Number of capacity steps		2	2	2	2	4	4	4	4	4	4
Minimum capacity	%	42	50	46	50	25	25	21	25	23	25
Control											
		Pro-Dialog Plus									
Condensers 30RW											
		Welded plate heat exchangers									
Water volume	l	-	-	-	-	-	-	34.9	34.9	46.6	46.6
Max. water-side operating pressure without hydronic module	kPa	-	-	-	-	-	-	1000	1000	1000	1000
with hydronic module	kPa	-	-	-	-	-	-	400	400	400	400
Condenser hydronic module, 30RW											
Condenser pump		One single or twin-head composite centrifugal pump, as per option used, variable speed by frequency converter (48.3 r/s)									
Power input	kW	-	-	-	-	-	-	6.7	6.7	6.7	6.7
Expansion tank volume, condenser loop	l	-	-	-	-	-	-	35	50	50	50
Evaporator, 30RW/30RWA											
		Welded direct-expansion plate heat exchanger									
Water volume	l	12.2	13.7	15.8	17.9	26.5	26.5	34.9	34.9	46.6	46.6
Max. water-side operating pressure without hydronic module	kPa	1000	1000	1000	1000	1000	1000	1000	1000	1000	1000
with hydronic module	kPa	400	400	400	400	400	400	400	400	400	400
Evaporator hydronic module, 30RW/30RWA											
Evaporator pump		One single or twin-head composite centrifugal pump, as per option used (48.3 r/s)									
Power input	kW	2.5	2.5	2.5	2.5	5.0	5.0	5.0	5.0	5.0	5.0
Expansion tank volume, evaporator loop	l	25	25	25	25	35	35	35	50	50	50
Field water connections, 30RW/30RWA											
		Victaulic****									
Standard customer connection diameter	in	3 OD	3 OD	3 OD	3 OD	3	3	3	3	3	3
Welded connection diameter	mm	76.1	76.1	76.1	76.1	88.9	88.9	88.9	88.9	88.9	88.9
Field refrigerant connection, 30RWA											
		Welded copper tube									
Discharge piping outside diameter	in										
Circuit A		1-3/8	1-3/8	1-3/8	1-3/8	1-3/8	1-3/8	1-3/8	1-3/8	1-3/8	1-3/8
Circuit B		-	-	-	-	1-3/8	1-3/8	1-3/8	1-3/8	1-3/8	1-3/8
Liquid refrigerant return piping OD	in										
Circuit A		7/8	1-1/8	1-1/8	1-1/8	1-1/8	1-1/8	1-1/8	1-1/8	1-1/8	1-1/8
Circuit B		-	-	-	-	1-1/8	1-1/8	1-1/8	1-1/8	1-1/8	1-1/8

* Standard EUROVENT conditions: evaporator entering/leaving water temperature = 12°C/7°C, condenser entering/leaving water temperature = 30°C/35°C.

** Standard EUROVENT conditions: evaporator entering/leaving water temperature = 12°C/7°C, saturated bubble point condensing temperature = 45°C, subcooling = 5 K.

*** The RWA units only have a nitrogen holding charge

**** With tubular sleeve, supplied with the unit, consisting of a Victaulic connection at one end and a plain section at the other end.

4.2 - Electrical data

30RW/RWA (without hydronic module)		110	120	135	150	160	185	210	245	275	300
Power circuit											
Nominal voltage	V-ph-Hz	400-3-50									
Voltage range	V	360-440									
Control circuit supply											
The control circuit is supplied via the unit-mounted transformer											
Maximum power input, 30RW and 30RWA*	kW	42.4	48.8	54.0	59.1	63.2	72.2	84.9	97.6	107.9	118.2
Nominal current draw											
30RW**	A	48.1	54.0	61.0	68.0	71.7	84.2	96.1	108.0	122.0	136.0
30RWA***	A	51.4	58.0	64.7	71.4	76.3	89.6	102.8	116.0	129.4	142.8
Maximum current draw											
30RW and 30RWA****	A	69.2	78.0	87.0	96.0	104	120.9	138.5	156.0	174.0	192.0
Max. start-up current (standard unit without electronic starter, 30RW and 30RWA†)	A	245.2	254.0	309.0	318.0	212.6	245.7	314.5	332.0	396.0	414.0
Max. start-up current (unit with optional electronic starter), 30 RW and 30RWA‡	A	159.2	168.0	201.0	210.0	158.6	183.7	228.5	246.0	288.0	306.0
Holding current for three-phase short circuits 30RW/RWA	kA	10	10	10	10	18	18	18	18	18	18

- * Power input of the compressor(s) at maximum unit operating conditions: entering/leaving evaporator water temperature = 15°C/10°C, maximum condensing temperature of 65°C, and 400 V nominal voltage.
- ** Nominal unit current draw at standard conditions: evaporator entering/leaving water temperature 12°C/7°C, condenser entering/leaving water temperature 30°C/35°C. The current values are given at 400 V nominal voltage.
- *** Nominal unit current draw at standard conditions: evaporator entering/leaving water temperature 12°C/7°C, saturated condensing temperature (dew point) 45°C, subcooling 5 K. The current values are given at 400 V nominal voltage.
- **** Maximum unit operating current at maximum unit power input and 400 V.
- † Maximum instantaneous starting current at 400 V nominal voltage and with compressor in across-the-line start (maximum operating current of the smallest compressor(s) + locked rotor current of the largest compressor).
- ‡ Maximum instantaneous starting current at 400 V nominal voltage and with compressor with electronic starter (maximum operating current of the smallest compressor(s) + reduced start-up current of the largest compressor).

Electrical data notes and operating conditions:

- 30RW and 30RWA units have a single power connection point.
- The control box includes the following standard features:
 - the starter and motor protection devices for each compressor and the pumps
 - the control devices
- Field connections:
 - All connections to the system and the electrical installations must be in full accordance with all applicable local codes.
- The Carrier 30RW and 30RWA units are designed and built to ensure conformance with these codes. The recommendations of European standard EN 60204-1 (machine safety - electrical machine components - part 1: general regulations - corresponds to IEC 60204-1) are specifically taken into account, when designing the electrical unit equipment.

NOTES:

- Generally the recommendations of IEC 60364 are accepted as compliance with the requirements of the installation directives. Conformance with EN 60204-1 is the best means of ensuring compliance with the Machines Directive § 1.5.1.
 - Annex B of EN 60204-1 describes the electrical characteristics used for the operation of the machines.
- The operating environment for the 30RW and 30RWA chillers is specified below:
 - Environment* - Environment as classified in IEC 60364 § 3:
 - ambient temperature range: +5°C to +40°C, class AA4
 - humidity range (non-condensing)*:
 - 50% relative humidity at 40°C
 - 90% relative humidity at 20°C
 - altitude: ≤ 2000 m (see note for table 4.3 - Electrical data, hydronic module)
 - indoor installation*

- presence of water: class AD2* (possibility of water droplets)
 - presence of hard solids, class AE2* (no significant dust present)
 - presence of corrosive and polluting substances, class AF1 (negligible)
 - vibration and shock, class AG2, AH2
 - competence of personnel, class BA4* (trained personnel - IEC 60364)
- Power supply frequency variation: ± 2 Hz.
 - The neutral (N) conductor must not be connected directly to the unit (if necessary use a transformer).
 - Over-current protection of the power supply conductors is not provided with the unit.
 - The factory-installed disconnect switch(es)/circuit breaker(s) is (are) of a type suitable for power interruption in accordance with EN 60947.
 - The units are designed for simplified connection on TN(s) networks (IEC 60364). For IT networks provide a local earth and consult competent local organisations to complete the electrical installation.
 - Derived currents: If protection by monitoring of derived currents is necessary to ensure the safety of the installation, the control of the cut-out value must take the presence of leak currents into consideration that result from the use of frequency converters in the unit. A value of at least 150 mA is recommended to control differential protection devices.

NOTE: If particular aspects of an actual installation do not conform to the conditions described above, or if there are other conditions which should be considered, always contact your local Carrier representative.

- * The protection level of the control boxes required to conform to this class is IP21 B (according to reference document IEC 60529). All 30RW and 30RWA units with correctly installed casing panels fulfil this protection condition.

4.3 - Electrical data, optional hydronic module

The pumps that are factory-installed in these units comply with the European Ecodesign directive ErP. The additional electrical data required is as follows:*

Motors of evaporator hydronic module pumps, 30RW/30RWA (option 116B)

No.**	Description***	30RW/30RWA										
		110	120	135	150	160	185	210	245	275	300	
1	Nominal efficiency at full load and nominal voltage	%	85,9	85,9	85,9	85,9	88,1	88,1	88,1	88,1	88,1	88,1
1	Nominal efficiency at 75% rated load and nominal voltage	%	85,9	85,9	85,9	85,9	88	88	88	88	88	88
1	Nominal efficiency at 50% rated load and nominal voltage	%	84,5	84,5	84,5	84,5	86,1	86,1	86,1	86,1	86,1	86,1
2	Efficiency level		IE3									
3	Year of manufacture		This information varies depending on the manufacturer and model at the time of incorporation. Please refer to the motor name plates.									
4	Manufacturer's name and trademark, commercial registration number and place of manufacturer		This information varies depending on the manufacturer and model at the time of incorporation. Please refer to the motor name plates.									
5	Product's model number											
6	Number of motor poles		2	2	2	2	2	2	2	2	2	2
7-1	Rated shaft power output at full load and nominal voltage (400 V)	kW	2,2	2,2	2,2	2,2	4	4	4	4	4	4
7-2	Maximum power input (400 V)****	kW	2,56	2,56	2,56	2,56	4,54	4,54	4,54	4,54	4,54	4,54
8	Rated input frequency	Hz	50	50	50	50	50	50	50	50	50	50
9-1	Rated voltage	V	3x400									
9-2	Maximum current drawn (400 V)†	A	4,5	4,5	4,5	4,5	7,4	7,4	7,4	7,4	7,4	7,4
10	Rated speed		48-2880	48-2880	48-2880	48-2880	49-2915	49-2915	49-2915	49-2915	49-2915	49-2915
11	Product disassembly, recycling or disposal at end of life		Disassembly using standard tools. Disposal and recycling using an appropriate company.									
12	Operating conditions for which the motor is specifically designed											
	I - Altitudes above sea level	m	< 1000††									
	II - Ambient air temperature	°C	< 40									
	IV - Maximum air temperature	°C	Please refer to the operating conditions given in this manual or in the specific conditions in the Carrier selection programs.									
	V - Potentially explosive atmospheres		Non-ATEX environment									

Motors of evaporator hydronic module pumps, 30RW/30RWA (option 116C)

No.**	Description***	30RW/RWA										
		110	120	135	150	160	185	210	245	275	300	
1	Nominal efficiency at full load and nominal voltage	%	88,1	88,1	88,1	88,1	88,1	88,1	89,4	89,4	89,4	89,4
1	Nominal efficiency at 75% rated load and nominal voltage	%	88	88	88	88	88	88	88,9	88,9	88,9	88,9
1	Nominal efficiency at 50% rated load and nominal voltage	%	86,1	86,1	86,1	86,1	86,1	86,1	86,7	86,7	86,7	86,7
2	Efficiency level		IE3									
3	Year of manufacture		This information varies depending on the manufacturer and model at the time of incorporation. Please refer to the motor name plates.									
4	Manufacturer's name and trademark, commercial registration number and place of manufacturer		This information varies depending on the manufacturer and model at the time of incorporation. Please refer to the motor name plates.									
5	Product's model number											
6	Number of motor poles		2	2	2	2	2	2	2	2	2	2
7-1	Rated shaft power output at full load and nominal voltage (400 V)	kW	4	4	4	4	4	4	5,5	5,5	5,5	5,5
7-2	Maximum power input (400 V)****	kW	4,54	4,54	4,54	4,54	4,54	4,54	6,15	6,15	6,15	6,15
8	Rated input frequency	Hz	50	50	50	50	50	50	50	50	50	50
9-1	Rated voltage	V	3x400									
9-2	Maximum current drawn (400 V)†	A	7,4	7,4	7,4	7,4	7,4	7,4	9,7	9,7	9,7	9,7
10	Rated speed		49-2915	49-2915	49-2915	49-2915	49-2915	49-2915	49-2930	49-2930	49-2930	49-2930
11	Product disassembly, recycling or disposal at end of life		Disassembly using standard tools. Disposal and recycling using an appropriate company.									
12	Operating conditions for which the motor is specifically designed											
	I - Altitudes above sea level	m	< 1000††									
	II - Ambient air temperature	°C	< 40									
	IV - Maximum air temperature	°C	Please refer to the operating conditions given in this manual or in the specific conditions in the Carrier selection programs.									
	V - Potentially explosive atmospheres		Non-ATEX environment									

* Required by regulation 640/2009 with regard to the application of directive 2009/125/EC on the eco-design requirements for electric motors

** Item number imposed by regulation 640/2009, annex I2b.

*** Description given by regulation 640/2009, annex I2b.

**** To obtain the maximum power input for a unit with hydronic module add the maximum unit power input from the electrical data table to the pump power input.

† To obtain the maximum unit operating current draw for a unit with hydronic module add the maximum unit current draw from the electrical data table to the pump current draw.

†† Above 1000 m, a degradation of 3% for each 500 m should be taken into consideration.

The pumps that are factory-installed in these units comply with the European Ecodesign directive ErP. The additional electrical data required* is as follows:

Motors of condenser hydronic module pumps, 30RW (option 270B, variable-speed pump)

No.**	Description***		30RW/RWA									
			110	120	135	150	160	185	210	245	275	300
1	Nominal efficiency at full load and nominal voltage	%	88,1	88,1	88,1	88,1	88,1	88,1	89,2	89,2	89,2	89,2
1	Nominal efficiency at 75% rated load and nominal voltage	%	88	88	88	88	88	88	88,9	88,9	88,9	88,9
1	Nominal efficiency at 50% rated load and nominal voltage	%	86,1	86,1	86,1	86,1	86,1	86,1	87,9	87,9	87,9	87,9
2	Efficiency level		IE3									
3	Year of manufacture		This information varies depending on the manufacturer and model at the time of incorporation. Please refer to the motor name plates.									
4	Manufacturer's name and trademark, commercial registration number and place of manufacturer		refer to the motor name plates.									
5	Product's model number											
6	Number of motor poles		2	2	2	2	2	2	2	2	2	2
7-1	Rated shaft power output at full load and nominal voltage (400 V)	kW	4	4	4	4	4	4	5,5	5,5	5,5	5,5
7-2	Maximum power input (400 V)****	kW	4,54	4,54	4,54	4,54	4,54	4,54	6,17	6,17	6,17	6,17
8	Rated input frequency	Hz	50	50	50	50	50	50	50	50	50	50
9-1	Rated voltage	V	3x400									
9-2	Maximum current drawn (400 V)†	A	7,4	7,4	7,4	7,4	7,4	7,4	10,5	10,5	10,5	10,5
10	Rated speed		49-2915	49-2915	49-2915	49-2915	49-2915	49-2915	49-2917	49-2917	49-2917	49-2917
11	Product disassembly, recycling or disposal at end of life		Disassembly using standard tools. Disposal and recycling using an appropriate company.									
12	Operating conditions for which the motor is specifically designed											
	I - Altitudes above sea level	m	< 1000††									
	II - Ambient air temperature	°C	< 40									
	IV - Maximum air temperature	°C	Please refer to the operating conditions given in this manual or in the specific conditions in the Carrier selection programs.									
	V - Potentially explosive atmospheres		Non-ATEX environment									

Motors of condenser hydronic module pumps, 30RW (option 270C, variable-speed pump)

No.**	Description***		30RW/RWA									
			110	120	135	150	160	185	210	245	275	300
1	Nominal efficiency at full load and nominal voltage	%	88,1	88,1	88,1	88,1	88,1	88,1	89,2	89,2	89,2	89,2
1	Nominal efficiency at 75% rated load and nominal voltage	%	88	88	88	88	88	88	88,9	88,9	88,9	88,9
1	Nominal efficiency at 50% rated load and nominal voltage	%	86,1	86,1	86,1	86,1	86,1	86,1	87,9	87,9	87,9	87,9
2	Efficiency level		IE3									
3	Year of manufacture		This information varies depending on the manufacturer and model at the time of incorporation. Please refer to the motor name plates.									
4	Manufacturer's name and trademark, commercial registration number and place of manufacturer		refer to the motor name plates.									
5	Product's model number											
6	Number of motor poles		2	2	2	2	2	2	2	2	2	2
7-1	Rated shaft power output at full load and nominal voltage (400 V)	kW	4	4	4	4	4	4	5,5	5,5	5,5	5,5
7-2	Maximum power input (400 V)****	kW	4,54	4,54	4,54	4,54	4,54	4,54	6,17	6,17	6,17	6,17
8	Rated input frequency	Hz	50	50	50	50	50	50	50	50	50	50
9-1	Rated voltage	V	3x400									
9-2	Maximum current drawn (400 V)†	A	7,4	7,4	7,4	7,4	7,4	7,4	10,5	10,5	10,5	10,5
10	Rated speed		49-2915	49-2915	49-2915	49-2915	49-2915	49-2915	49-2917	49-2917	49-2917	49-2917
11	Product disassembly, recycling or disposal at end of life		Disassembly using standard tools. Disposal and recycling using an appropriate company.									
12	Operating conditions for which the motor is specifically designed											
	I - Altitudes above sea level	m	< 1000††									
	II - Ambient air temperature	°C	< 40									
	IV - Maximum air temperature	°C	Please refer to the operating conditions given in this manual or in the specific conditions in the Carrier selection programs.									
	V - Potentially explosive atmospheres		Non-ATEX environment									

* Required by regulation 640/2009 with regard to the application of directive 2009/125/EC on the eco-design requirements for electric motors

** Item number imposed by regulation 640/2009, annex I2b.

*** Description given by regulation 640/2009, annex I2b.

**** To obtain the maximum power input for a unit with hydronic module add the maximum unit power input from the electrical data table to the pump power input.

† To obtain the maximum unit operating current draw for a unit with hydronic module add the maximum unit current draw from the electrical data table to the pump current draw.

†† Above 1000 m, a degradation of 3% for each 500 m should be taken into consideration.

4.4 - Compressor usage and electrical data table

Compressor reference	I Nom	I Max	LRA	Circ.	30RW/30RWA									
					110	120	135	150	160	185	210	245	275	300
DQ 12 CA 025 EE	9.9	13.7	86	A B										
DQ 12 CA 001 EE	12.6	17.6	130	A B										
DQ 12 CA 002 EE	14.6	20.4	130	A B										
DQ 12 CA 031 EE	17.9	25.9	135	A B					A1 + A2 A1 + A2					
DQ 12 CA 032 EE	21.1	30.2	155	A B	A1					A1 + A2 A1 + A2	A1 B1			
DQ 12 CA 027 EE	27	39	215	A B	A2	A1 + A2	A1				A2 B2	A1 + A2 B1 + B2	A1 B1	
DQ 12 CA 028 EE	34	48	270	A B			A2	A1 + A2					A2 B2	A1 + A2 B1 + B2

Legend

I Nom Nominal current draw (A) at standard Eurovent conditions (see definition of conditions under nominal unit current draw)

I Max Maximum operating current (A) at 400 V

LRA Locked rotor current (A)

5 - APPLICATION DATA

5.1 - Operating limits 30RW/RWA

30RW/30RWA Evaporator	Entering water temp., °C		Leaving water temp., °C	
	Minimum	Maximum	Minimum	Maximum
At start-up	7.5	30	5 (note 1)	15
At shut-down	-	50	-	50
During operation	5 (note 1)	15	50	50

30RW Condenser	Entering water temperature, °C	Leaving water temperature, °C
With hydronic module and variable-speed pump		
At start-up/during operation (min.)	-15	-
During operation (max.)	47 (note 3)	52
Without hydronic module		
At start-up/during operation (min.)	20 (note 2)	25
During operation (max.)	47 (note 3)	52

30RW Drycooler	Entering air temperature, °C
With hydronic module and variable-speed pump	
At start-up/during operation (min.)	-20 (note 4)
During operation (max.)	
Without hydronic module	
At start-up/during operation (min.)	(note 5)
During operation (max.)	(note 4)

30RWA Air-cooled condenser	Entering air temperature, °C	
At start-up/during operation	Minimum	Maximum
With variable-speed fan	-10	(note 6)
With fixed-speed fan	0	(note 6)

Notes

- 30RW/30RWA units can operate from 4°C to 0°C without modification. In all cases the units must be configured for low leaving-water temperature, and use of antifreeze is required.
- 30RW units without hydronic module operating below 20°C entering condenser water temperature require the use of a three-way valve controlled from the 0-10 V analogue output of the Pro-Dialog control.
- For a flow rate corresponding to a condenser Δt of 5 K.
- The maximum entering air temperature is based on the drycooler selection.
- The minimum entering air temperature range is between 15 and 20°C (without the use of three-way valves)
Operation at -15°C ambient temperature is possible with the use of a three-way valve to maintain the required minimum condensing temperature (see note 2).
- The maximum entering air temperature is based on the remote condenser selection.

IMPORTANT: Maximum ambient temperatures. For storage and transport of 30RW units the minimum and maximum temperatures must not go beyond -20°C and 50°C. It is recommended that these temperatures are used for transport by container.

5.2 - Operating range 30RW

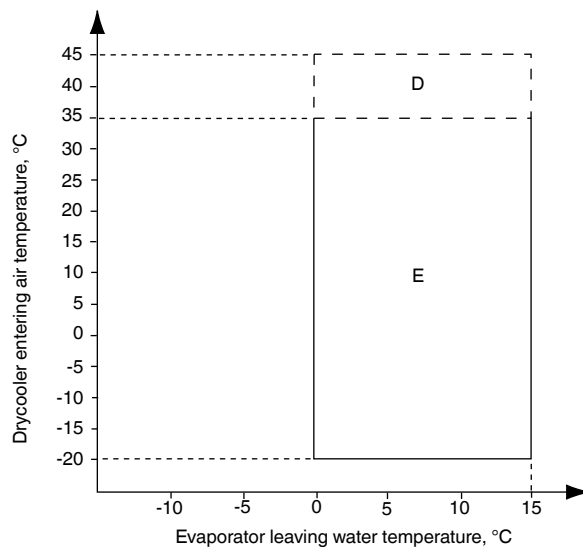
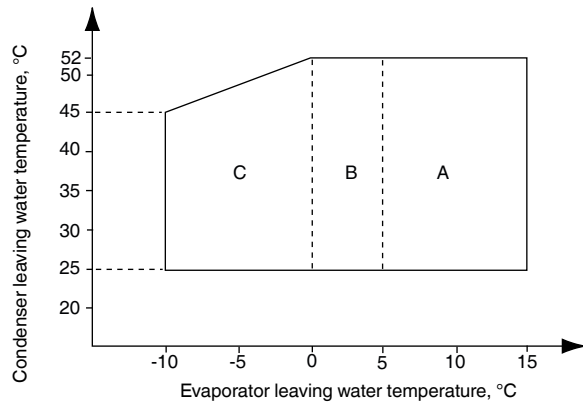

Notes 30RW

- Evaporator and condenser $\Delta T = 5$ K
- For 30RW units without hydronic module with an entering condenser water temperature below 20°C a three-way valve is required to allow operation, while maintaining the correct condensing temperature.
- For 30RW units equipped with a hydronic module the minimum entering water temperature is -15°C.
- Maximum leaving condenser water temperature is 52°C (at full load)

- A Standard unit with without antifreeze solution
- B Standard unit operation with the anti-freeze solution required and control configuration for a leaving water temperature down to 0°C.
- C Standard unit operation with the anti-freeze solution required and control configuration for a leaving water temperature down to -10°C.
- D Operation at high air temperature is based on the drycooler selected.
- E Operation at low air temperature is possible down to -20°C with a drycooler.

5.3 - Operating range 30RWA

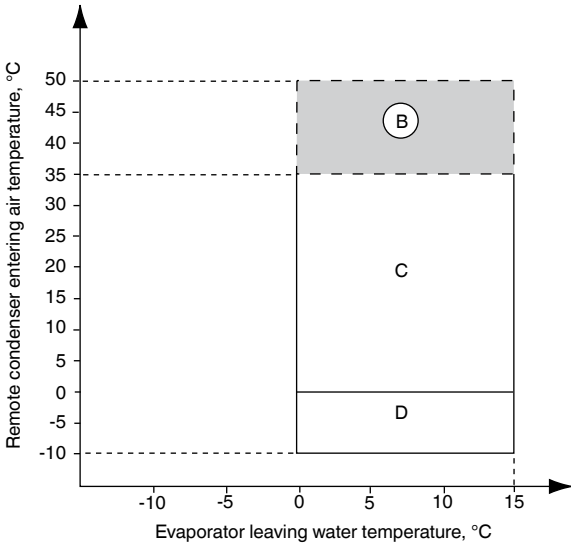
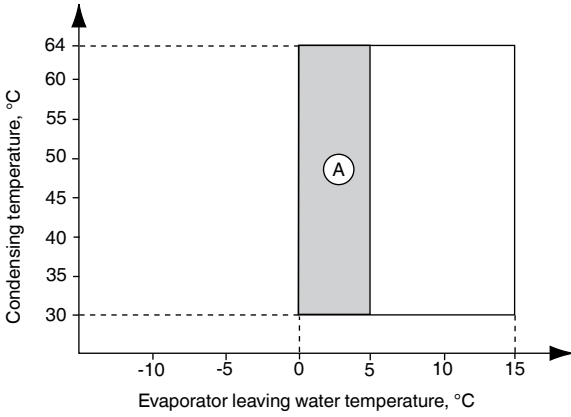

Notes 30RWA

- 1 Evaporator $\Delta T = 5$ K
 - 2 Unit operation is limited by the maximum compressor condensing temperature of 64°C.
- A Standard unit operation with the anti-freeze solution required and special control configuration.
- B Operation at high air temperature is based on the condenser selected.
- C Operating range down to 0°C, if the air-cooled condenser is not equipped with a variable-speed head fan.
- D Extended operating range with variable-speed fan.

5.4 - Minimum chilled water flow

If the system water flow rate is lower than the minimum water flow rate, recirculation of the evaporator flow may occur. The temperature of the mixture leaving the evaporator must never be less than 2.8 K lower than the chilled water entering temperature.

5.5 - Maximum chilled water flow

The maximum chilled water flow is limited by the maximum permitted pressure drop in the evaporator. It is provided in the table below. If the flow exceeds the maximum value, two solutions are possible:

- Modify the flow rate with the control valve.
- Bypass the evaporator to obtain a higher temperature difference with a lower evaporator flow rate.

5.6 - Variable flow evaporator

Variable evaporator flow can be used in standard chillers. The chillers maintain a constant leaving water temperature under all flow conditions. For this to happen, the minimum flow rate must be higher than the minimum flow given in the table of permissible flow rates and must not vary by more than 10% per minute.

If the flow rate changes more rapidly, the system should contain a minimum of 6.5 litres of water per kW instead of the values below.

5.7 - Evaporator flow rate

30RW /RWA	Minimum flow rate, l/s	Maximum flow rate, l/s*		Maximum flow rate, l/s**
		Single pump	Dual pump	
110	1.8	8.3	11.7	10.3
120	2.2	8.5	12.4	11.4
135	2.4	8.8	13.1	12.8
150	2.7	9.0	13.7	14.3
160	2.7	14.2	14.2	15.9
185	3.1	14.5	14.5	17.0
210	3.8	17.4	22.0	24.0
245	4.4	17.4	22.0	24.0
275	5.0	18.1	23.3	29.1
300	5.5	18.1	23.3	29.1

* Maximum flow rate for an available pressure of 50 kPa (unit with hydronic module)

** Maximum flow rate for a pressure drop of 100 kPa in the plate heat exchanger (unit without hydronic module)

5.8 - Condenser water flow rate (l/s)

30RW / RWA	Minimum flow rate* at min. condenser capacity - $\Delta t = 10$ K	Nom. condenser flow rate at Eurovent conditions	Maximum flow rate** at max. condenser capacity - $\Delta t = 5$ K
110	2.8	6.4	7.4
120	3.3	7.3	8.5
135	3.6	8.3	9.5
150	4.0	9.1	10.3
160	4.2	9.4	10.9
185	4.7	10.8	12.5
210	5.7	12.7	14.6
245	6.5	14.5	16.8
275	7.3	16.6	19.0
300	8.0	18.2	20.5

* The minimum flow rate given is for units without hydronic module that have a fixed condenser flow rate. Units with a hydronic module have a variable flow rate and no minimum fixed flow rate. The minimum flow rate is optimised by unit control in parallel with the drycooler fan stages for all operating conditions, especially at low outdoor temperature and low load conditions.

** The maximum flow rate given is for units without hydronic module that have a fixed condenser flow rate. Units with a hydronic module have a variable flow rate. The maximum flow rate is optimised by unit control at all operating conditions, based on pump capacity, system pressure losses and outdoor temperature.

5.9 - Minimum chilled water loop volume

Whichever the system, the water loop minimum capacity is given by the formula:

$$\text{Capacity} = \text{Cap (kW)} \times \text{N Liters}$$

Where Cap is the nominal system cooling capacity (kW) at the nominal operating conditions of the installation.

This volume is necessary for stable operation and accurate temperature control.

Application	N
Air conditioning 30RW/30RWA 110-300	2.5

Industrial process applications

Certain industrial processes may require high leaving water stability. In these cases the values above must be increased.

It may be necessary to add a buffer water tank to the circuit in order to achieve the required volume. The tank must itself be internally baffled in order to ensure proper mixing of the liquid (water or brine). Refer to the examples below.

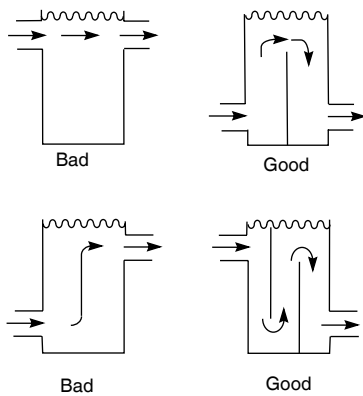

5.10 - Maximum water loop volume (evaporator and condenser side)

Units with hydronic module incorporate an expansion tank sized for the maximum water loop volume.

The table below gives the maximum water loop volume (in litres) for pure water or ethylene glycol with various concentrations.

30RW/RWA	110-150	160-210	245-300
Pure water	2080	2900	4162
10% ethylene glycol	1525	2135	3053
20% ethylene glycol	1120	1570	2236
35% ethylene glycol	910	1260	1800

5.11 - Minimum hot water loop volume

The condenser water loop volume has no impact on the chiller operation. For heat pump operation (unit control based on the hot-water temperature) the minimum condenser water loop volume must be calculated in accordance with the method used for the evaporator loop, replacing the cooling capacity with the heating capacity.

5.12 - Evaporator and condenser pressure drop curves

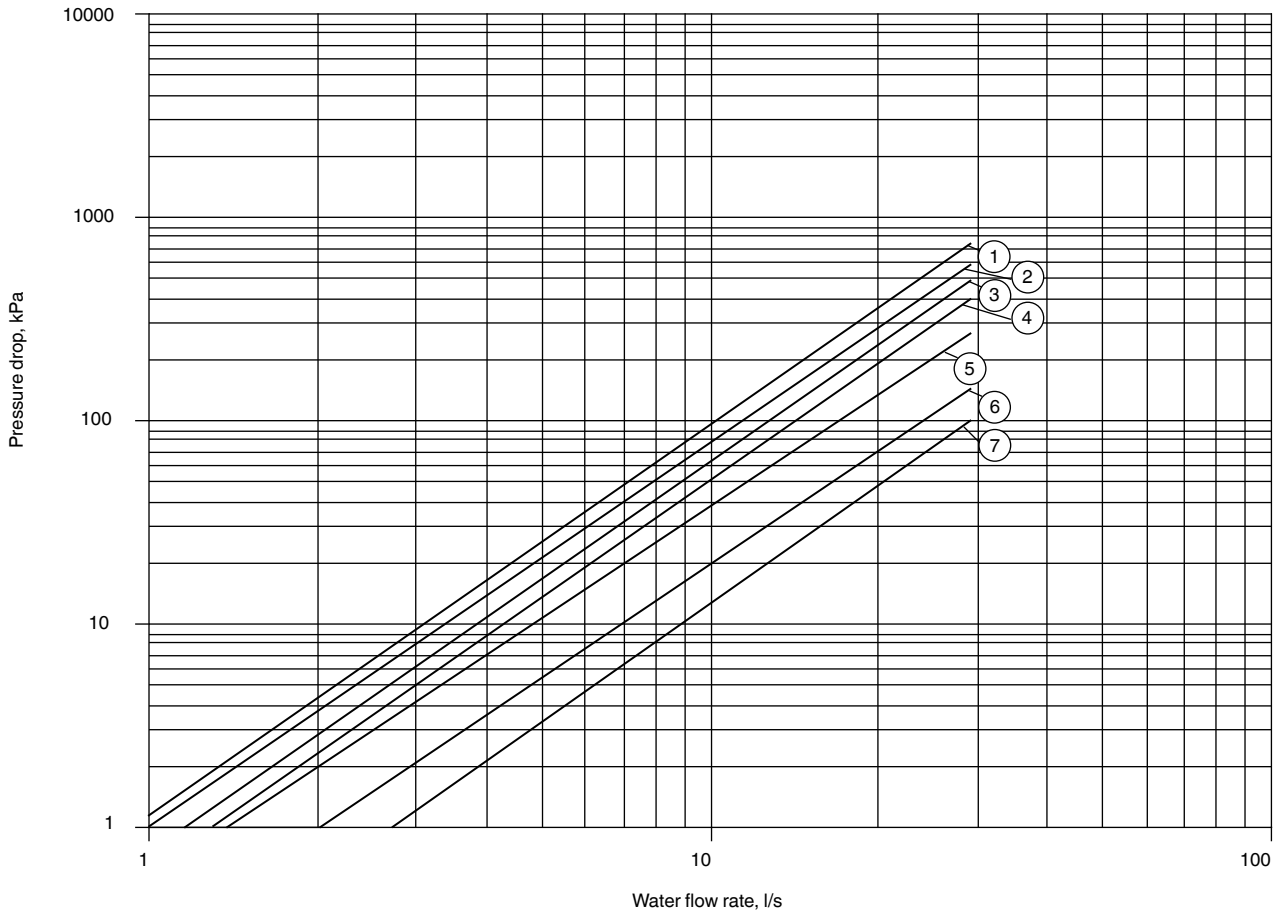

Legend

- 1 30RW 110
- 2 30RW 120
- 3 30RW 135
- 4 30RW 150
- 5 30RW 160-185
- 6 30RW 210-245
- 7 30RW 275-300

6 - ELECTRICAL CONNECTION

6.1 - Electrical connections 30RW/30RWA units

Control box 30RWA 110-150

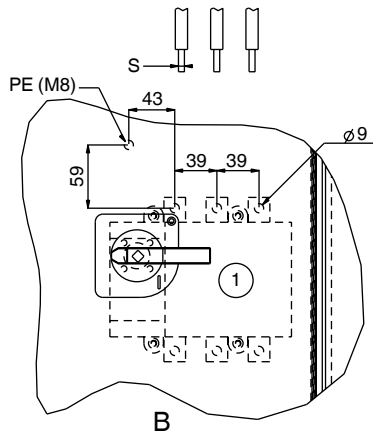
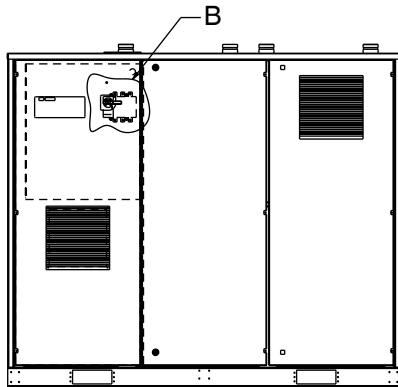

Control box 30RW/30RWA 160-300

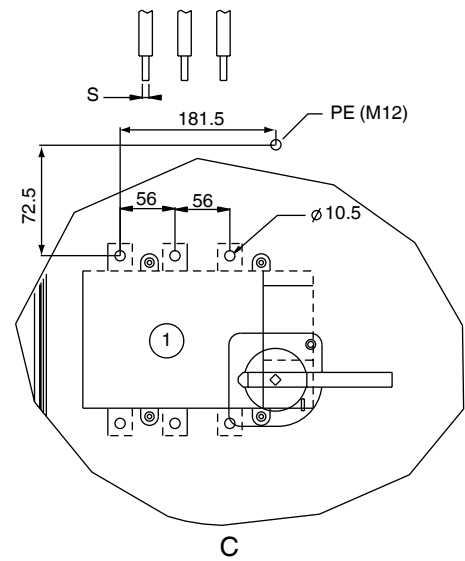
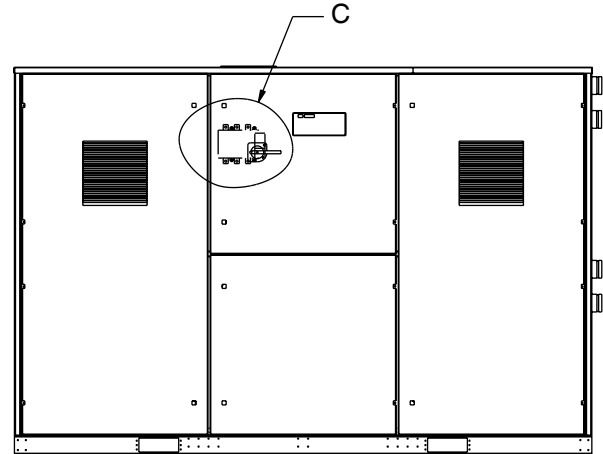

Legend

- 1 Main disconnect switch
- PE Earth connection
- S Power supply cable section (see table "Recommended wire sections").

NOTES:

The 30RW/30RWA 110-300 units have only one power connection point located at the main disconnect switch.
Before connecting electric power cables, it is imperative to check the correct order of the 3 phases (L1 - L2 - L3).
Non-certified drawings.

Refer to the certified dimensional drawings.

6.2 - Power supply

The power supply must conform to the specification on the chiller nameplate. The supply voltage must be within the range specified in the electrical data table. For connections refer to the wiring diagrams.

WARNING: Operation of the chiller with an improper supply voltage or excessive phase imbalance constitutes abuse which will invalidate the Carrier warranty. If the phase imbalance exceeds 2% for voltage, or 10% for current, contact your local electricity supply at once and ensure that the chiller is not switched on until corrective measures have been taken.

6.3 - Voltage phase imbalance (%)

$$\frac{100 \times \text{max. deviation from average voltage}}{\text{Average voltage}}$$

Example:

On a 400 V - 3 ph - 50 Hz supply, the individual phase voltages were measured to be:

AB = 406 V ; BC = 399 ; AC = 394 V

$$\begin{aligned} \text{Average voltage} &= (406 + 399 + 394)/3 = 1199/3 \\ &= 399.7 \text{ say } 400 \text{ V} \end{aligned}$$

Calculate the maximum deviation from the 400 V average:

$$(AB) = 406 - 400 = 6$$

$$(BC) = 400 - 399 = 1$$

$$(CA) = 400 - 394 = 6$$

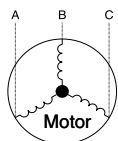

The maximum deviation from the average is 6 V. The greatest percentage deviation is: $100 \times 6/400 = 1.5 \%$

This is less than the permissible 2% and is therefore acceptable.

6.4 - Recommended wire sections

Wire sizing is the responsibility of the installer, and depends on the characteristics and regulations applicable to each installation site. The following is only to be used as a guide-line, and does not make Carrier in any way liable. After wire sizing has been completed, using the certified dimensional drawing, the installer must ensure easy connection and define any modifications necessary on site.

The connections provided as standard for the field-supplied power entry cables to the general disconnect/isolator switch are designed for the number and type of wires, listed in the table below.

The calculations are based on the maximum machine current (see electrical data tables). For the design the following standardised installation methods are used, in accordance with IEC 60364, table 52C:

- For units installed inside the building:
No.13: perforated horizontal cable conduit, and No. 41: closed conduit.

The calculation is based on PVC or XLPE insulated cables with copper or aluminium core. A maximum ambient temperature of 40°C has been taken into account. The given wire length limits the voltage drop to < 5%.

IMPORTANT: Before connection of the main power cables (L1 - L2 - L3) on the terminal block, it is imperative to check the correct order of the 3 phases before proceeding to the connection on then terminal block or the main disconnect/ isolator switch.

6.4.1 - Selection table of minimum and maximum wire sections for connection to 30RW/RWA units

400 V-3 ph-50 Hz

30RW/30RWA	Minimum wire section (mm ²)	Wire type	L (m)	Maximum wire section (mm ²)	Wire type	L (m)
110	1x 25	XLPE Cu	135	1x70	PVC Al	230
120	1x 25	XLPE Cu	130	1x70	PVC Al	230
135	1x 35	XLPE Cu	145	1x95	PVC Al	250
150	1x 35	XLPE Cu	145	1x95	PVC Al	250
160	1x 35	XLPE Cu	142	1x120	PVC Al	260
185	1x 50	XLPE Cu	162	1x120	XLPE Al	205
210	1x 70	XLPE Cu	175	1x120	XLPE Al	205
245	1x 70	XLPE Cu	170	1x150	XLPE Al	210
275	1x 70	XLPE Cu	168	1x150	XLPE Al	210
300	1x 95	XLPE Cu	180	1x185	XLPE Al	220

6.4.2 - Field control wiring

Refer to the 30RW/RWA Pro-Dialog Plus Controls IOM and the certified wiring diagram supplied with the unit for the field control wiring of the following features:

- Evaporator pump interlock (mandatory). Unit without hydronic module
- Remote on/off switch
- Remote heat/cool switch
- Demand limit external switch 1

- Remote dual set point
- Alarm report by circuit
- Evaporator pump control. Unit without hydronic module.
- Condenser pump control. Unit without hydronic module.

7 - WATER CONNECTIONS

For size and position of the heat exchanger water inlet and outlet connections refer to the certified dimensional drawings supplied with the unit. The water pipes must not transmit any radial or axial force to the heat exchangers nor any vibration.

The water supply must be analysed and appropriate filtering, treatment, control devices, isolation and bleed valves and circuits built in, to prevent corrosion, fouling and deterioration of the pump fittings. Consult either a water treatment specialist or appropriate literature on the subject.

7.1 - Operating precautions

The water circuit should be designed to have the least number of elbows and horizontal pipe runs at different levels. Below the main points to be checked for the connection:

- Comply with the water inlet and outlet connections shown on the unit.
- Install manual or automatic air purge valves at all high points in the circuit(s).
- Use a pressure reducer to maintain pressure in the circuit(s) and install a safety valve as well as an expansion tank. Units with hydronic module include the safety valve and expansion tank.
- Install thermometers in both the entering and leaving water connections.
- Install drain connections at all low points to allow the whole circuit to be drained.
- Install stop valves, close to the entering and leaving water connections.
- Use flexible connections to reduce the transmission of vibrations.
- Insulate all pipework, after testing for leaks, both to reduce thermal leaks and to prevent condensation.
- Cover the insulation with a vapour barrier. If the external water piping to the unit is in an area where the ambient temperature can fall below 0°C, it should be insulated and an electric heater should be installed on the piping.

NOTE: For units without hydronic module a screen filter must be installed as close as possible to the heat exchanger and in a position that is easily accessible for removal and cleaning. Units with a hydronic module are equipped with this filter.

The mesh size of the filter must be 1.2 mm. If this filter is not installed, the plate heat exchanger can quickly become contaminated at the first start-up, as it takes on the filter function, and correct unit operation is affected (reduced water flow due to increased pressure drop).

Before the system start-up verify that the water circuits are connected to the appropriate heat exchangers (e.g. no reversal between evaporator and condenser).

Do not introduce any significant static or dynamic pressure into the heat exchange circuit (with regard to the design operating pressures).

Before any start-up verify that the heat exchange fluid is compatible with the materials and the water circuit coating.

In case additives or other fluids than those recommended by Carrier are used, ensure that the fluids are not considered as a gas, and that they belong to class 2, as defined in directive 97/23/EC.

Carrier recommendations on heat exchange fluids:

- No NH_4^+ ammonium ions in the water, they are very detrimental for copper. This is one of the most important factors for the operating life of copper piping. A content of several tenths of mg/l will badly corrode the copper over time (the plate heat exchangers used for these units have brazed copper joints).
- Cl^- Chloride ions are detrimental for copper with a risk of perforations by corrosion by puncture. If possible keep below 10 mg/l.
- SO_4^{2-} sulphate ions can cause perforating corrosion, if their content is above 30 mg/l.
- No fluoride ions (<0.1 mg/l).
- No Fe^{2+} and Fe^{3+} ions with non negligible levels of dissolved oxygen must be present. Dissolved iron < 5 mg/l with dissolved oxygen < 5 mg/l.
- Dissolved silicon: silicon is an acid element of water and can also lead to corrosion risks. Content < 1mg/l.
- Water hardness: > 0.5 mmol/l. Values between 1 and 2.5 can be recommended. This will facilitate scale deposit that can limit corrosion of copper. Values that are too high can cause piping blockage over time. A total alkalimetric titre (TAC) below 100 is desirable.
- Dissolved oxygen: Any sudden change in water oxygenation conditions must be avoided. It is as detrimental to deoxygenate the water by mixing it with inert gas as it is to over-oxygenate it by mixing it with pure oxygen. The disturbance of the oxygenation conditions encourages destabilisation of copper hydroxides and enlargement of particles.
- Specific resistance – electric conductivity: the higher the specific resistance, the slower the corrosion tendency. Values above 30 Ohm·m are desirable. A neutral environment favours maximum specific resistance values. For electric conductivity values in the order of 20-60 mS/m can be recommended.
- pH: Ideal case pH neutral at 20-25°C
 $7 < \text{pH} < 8$

If the water circuit must be emptied for longer than one month, the complete circuit must be placed under nitrogen charge to avoid any risk of corrosion by differential aeration.

ATTENTION: Filling, completing and draining the water circuit charge must be done by qualified personnel, using the air purges and materials that are suitable for the products.

Charging and removing heat exchange fluids should be done with devices that must be included on the water circuit by the installer. Never use the unit heat exchangers to add heat exchange fluid.

7.2 - Water connections

The diagrams on the following page illustrate a typical hydronic installation. When the hydronic circuit is filled, use the air vents to evacuate any residual air pockets.

7.3 - Frost protection

The 30RW and 30RWA units are designed to be installed under cover at outside temperatures between +5°C and +40°C. Therefore they do not include anti-freeze protection, as standard.

If the water piping is in an area where the ambient temperature can fall below 0°C it is recommended to install a trace heater on the piping and to add an antifreeze solution to protect the unit and the water piping to a temperature of 10 K below the lowest temperature likely to be reached at the installation site.

Use only antifreeze solutions, approved for heat exchanger duty. If the system is not protected by an antifreeze solution and will not be used during the freezing weather conditions, draining of the cooler and outdoor piping is mandatory. Damage due to freezing is not covered by the warranty.

IMPORTANT: Depending on the climatic conditions in your area you must:

- **Add ethylene glycol with an adequate concentration to protect the installation up to a temperature of 10 K below the lowest temperature likely to occur at the installation site.**
- **If the unit is not used for an extended period, it is recommended to drain it, and as a safety precaution add ethylene glycol to the heat exchanger, using the heat exchanger water entering purge valve connection.**
- **At the start of the next season, refill the unit with water and add an inhibitor.**
- **For the installation of auxiliary equipment, the installer must comply with basic regulations, especially for minimum and maximum flow rates, which must be between the values listed in the operating limit table (application data).**
- **To avoid corrosion by differential aeration, the complete heat exchange circuit must be charged with nitrogen, if it is drained for longer than one month. If the heat exchange fluid does not comply with Carrier recommendations, the circuit must immediately be filled with nitrogen.**

7.4 - Evaporator flow switch and chilled water pump interlock (units without hydronic module)

IMPORTANT: On 30RW and 30RWA units, the unit water flow switch must be energised, and the chilled water pump interlock must be connected. Failure to follow this instruction will void the Carrier guarantee.

The flow switch is supplied, installed on the evaporator entering water pipe and preset at the factory to cut out when there is insufficient water flow.

Terminals 34 and 35 are provided for field installation of the chilled water pump interlock (auxiliary contact for pump operation to be wired on site).

Typical evaporator hydronic circuit piping diagram 30RW/30RWA 110-300

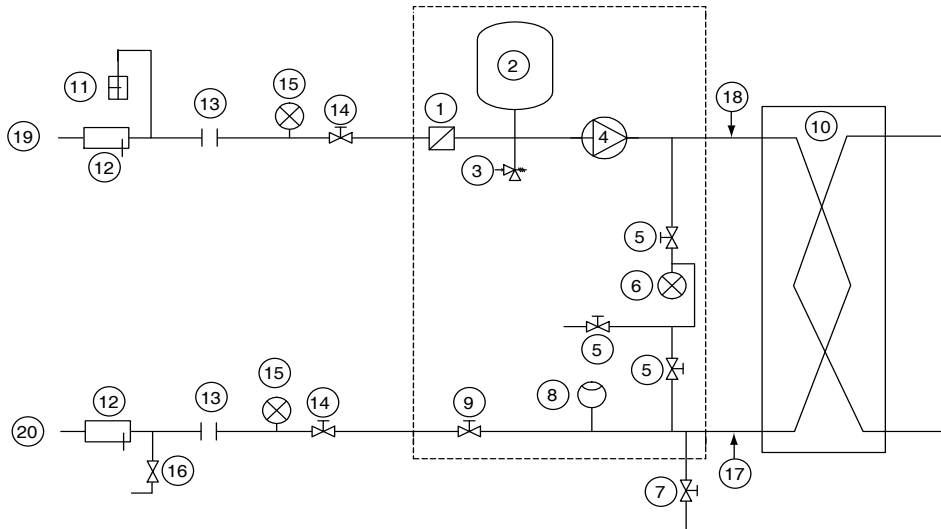

Legend

Components of unit and hydronic module

- 1 Victaulic screen filter
- 2 Expansion tank
- 3 Safety valve
- 4 Water pump
- 5 Purge valve and pressure tap
- 6 Pressure gauge to measure the plate heat exchanger pressure drop (to be isolated with valve No. 5 if not used)
- 7 Drain valve
- 8 Flow switch
- 9 Water flow control valve
- 10 Plate heat exchanger

Installation components

- 11 Air vent
- 12 Thermometer sleeve
- 13 Flexible connection
- 14 Shut-off valve
- 15 Pressure gauge
- 16 Charge valve
- 17 Plate heat exchanger outlet
- 18 Plate heat exchanger inlet
- 19 Water inlet
- 20 Water outlet

----- Hydronic module (units with hydronic module)

Note:

Units without hydronic module (option) are equipped with a flow switch and an internal piping heater.

Typical condenser hydronic circuit piping diagram 30RW 210-300

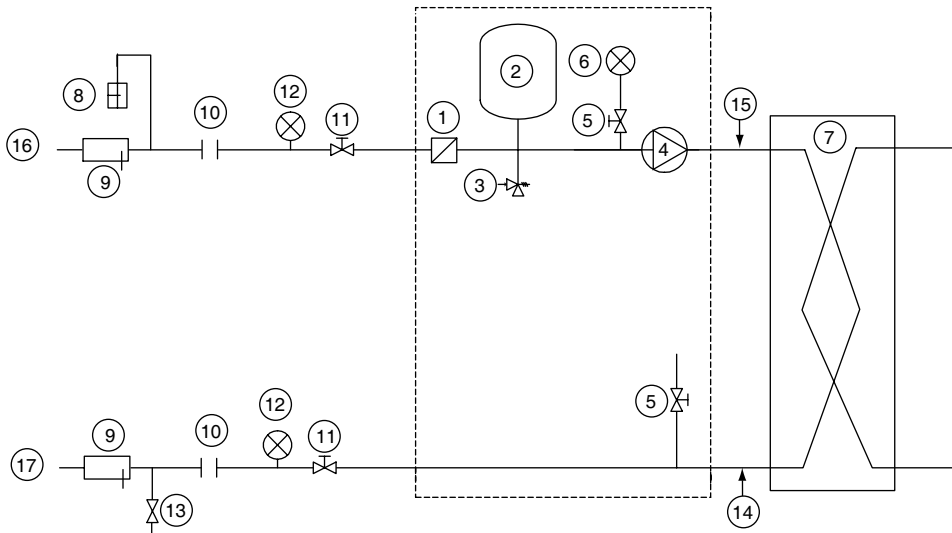

Legend

Components of unit and hydronic module

- 1 Victaulic screen filter
- 2 Expansion tank
- 3 Safety valve
- 4 Variable-speed water pump
- 5 Drain valve
- 6 Pressure gauge to measure the plate heat exchanger pressure drop (to be isolated with valve No. 5 if not used)
- 7 Plate heat exchanger

Installation components

- 8 Air vent
- 9 Thermometer sleeve
- 10 Flexible connection
- 11 Shut-off valve
- 12 Pressure gauge
- 13 Charge valve
- 14 Plate heat exchanger outlet
- 15 Plate heat exchanger inlet
- 16 Water inlet
- 17 Water outlet

----- Hydronic module (units with hydronic module)

8 - REFRIGERANT LINE CONNECTIONS (30RWA)

(Split units for connection to air-cooled condensers)

8.1 - Recommendations for the installation of liquid chillers with remote condensers

The 30RWA units (split units for connection to air-cooled condensers) have been specially designed to optimise the operation of split system installations, using air-cooled condensers as the chiller heat rejection system.

The installation of an operational system is limited to the connection of the air-cooled condenser inlet and outlet to the 30RWA unit. The components such as the non-return valve (in the discharge line), filter drier, moisture sight glass and solenoid valves are installed and wired in the factory.

The Pro-Dialog Plus control system of the 30RWA units incorporates the logic to permit control of the different fan versions (single-circuit, dual-circuit, fixed and variable-speed fan, separate ventilation or interlaced ventilation, i.e. common ventilation for both refrigerant circuits).

To guarantee optimum and reliable performance of the 30RWA units (split units for connection to air-cooled condensers) it is necessary to comply with the regulations described below, when these units are connected to remote condensers.

1. Size the discharge and liquid line piping according to the recommendations in the following paragraphs (if necessary, install a double riser to ensure correct oil circulation in the refrigerant circuit).
2. Select a condenser with an integrated subcooler to obtain a minimum of 3 K subcooling at the inlet to the expansion device.
3. Connect the fan stages electrically to the accessory control board, using the auxiliary board "AUX 1"; analogue inputs and outputs and discrete remote air-cooled condenser control outputs.

Refer to the paragraph on the description of the analogue and discrete inputs and outputs for the assignment of the fan stages.

4. Make the communication bus connection to the master basic board of the 30RW unit.
5. In the Pro-Dialog Plus control configure the number of fan stages and ventilation type in accordance with the air-cooled condenser model used in the installation.

A fan speed controller may be required for the first fan stage for operation at low ambient temperature and part load.

ATTENTION: The air-cooled condenser must always be used with a subcooler, normally with 8 K subcooling.

8.2 - General

Refrigerant pipe sizing must be carried out, taking account of the following constraints:

Oil return to the compressor must be ensured for the majority of applications. Oil return is ensured by entrainment. A minimum refrigerant velocity is required to ensure entrainment. This velocity depends on the pipe diameter, the refrigerant and oil temperature (these are treated as being the same in most cases). A reduction of the pipe diameter permits an increase of the refrigerant velocity. The problem of a minimum entrainment velocity does not exist for the pipes that carry liquid refrigerant as the oil is fully miscible here.

The pressure drop at the compressor discharge (pipes linking the compressor outlet with the condenser inlet) must be limited to avoid system performance losses (the compressor power input increases, and the cooling capacity decreases). As a first estimate and for standard air conditioning applications, a 1 K pressure drop on the discharge side decreases the cooling capacity 2% and increases the compressor power input by 3%.

Increasing the pipe diameter permits limiting the pressure drops.

The pressure drop in the liquid line (linking the condenser outlet to the expansion device) must not result in a change in phase.

The estimate of these pressure drops must include those generated by the filter drier, moisture sight glass and the solenoid valve, integrated into the 30RWA.

8.3 - Use of pipe sizing diagrams

In the annex to this document two pipe sizing diagrams are shown. They allow an estimate of the cooling capacity, corresponding to 1.5 K pressure drop for different pipe diameters, based on the pipe length.

The following procedure can be used for pipe sizing:

1. Measure the length (in metres) of the piping under consideration.
2. Add 40 to 50% to take account of special characteristics.
3. Multiply this length by the appropriate correction factor from Table 1 (this correction factor depends on the saturated suction and discharge temperatures).
4. Read the pipe size from diagrams "Discharge piping" and "Liquid line piping".
5. Calculate the equivalent lengths for parts included in the piping under consideration (such as valves, filters, connections).
The equivalent lengths are normally available from the component supplier. Add these lengths to the length calculated in step 3.
6. Repeat steps 4 and 5 if necessary.

The diagrams in the appendix can obviously be used to calculate the actual pressure drops for the piping under consideration:

7. Based on the pipe diameter and the cooling capacity find the equivalent length, producing 1.5 K pressure drop in the graphs "Discharge piping" and "Liquid line piping"
8. Calculate the equivalent pipe length as described in steps 1, 2, 3 and 5.
9. Calculate the length ratio from steps 8 and 7 (equivalent length from step 8 DIVIDED by the equivalent length from step 7).
10. Multiply this ratio by 1.5 to find the equivalent pressure drops in K.

8.4 - Discharge pipe sizing

The discharge piping must be sized to achieve reasonable pressure drops: a variation of 1.5 K of the saturated temperature is normally accepted (approx. 60 kPa variation for a condensing temperature of 50°C).

For most applications the refrigerant gas velocity is sufficient to entrain the liquid refrigerant/oil mixture. Nevertheless, Table 2 shows the minimum required cooling capacities for different pipe diameters and different saturated discharge temperatures.

This table is based on 8 K superheat, a saturated suction temperature of 4°C and 8 K subcooling. Table 3 shows the correction factors to be applied to the values from Table 2, if the operating conditions are different from those previously stated.

8.5 - Liquid pipe sizing

The 30RWA compressors are supplied with an oil that is fully miscible with refrigerant R-407C in the liquid phase. Consequently low refrigerant velocities in the liquid lines are not a problem.

The admissible pressure drops in the liquid lines depend mainly on the subcooling level of the liquid refrigerant at the condenser outlet. Pressure drops corresponding to 1.5°C saturated temperature must not be exceeded.

Special attention must be paid to the liquid line sizing when the expansion device is positioned higher than the condenser. It may now be necessary to increase the pipe diameter to compensate for the additional pressure of the liquid refrigerant column. If the liquid refrigerant head is very high, it may even be necessary to increase the subcooling to prevent a phase change in the liquid line. This can be done e.g. by a liquid-vapour heat exchanger or an additional coil.

At 45°C the volume mass of refrigerant R-407C in the liquid phase is approximately 1050 kg/m³. A pressure of 1 bar corresponds to a liquid head of: $100\,000 / (1050 \times 9.81) = 9.7$ m.

Table 1 - R-407C correction factors for copper tube, 30RWA

Condensing temperature, °C	Saturated suction temperature, °C																	
	-18			-12			-7			-1			4			10		
	S	HG	L	S	HG	L	S	HG	L	S	HG	L	S	HG	L	S	HG	L
27	2.01	1.36	1.09	1.61	1.34	1.07	1.31	1.30	1.06	1.07	1.26	1.04	0.89	1.23	1.03	0.74	1.19	1.01
32	2.11	1.27	1.08	1.69	1.23	1.06	1.37	1.19	1.04	1.12	1.16	1.03	0.93	1.12	1.01	0.77	1.09	1.00
38	2.22	1.17	1.08	1.78	1.13	1.06	1.44	1.10	1.04	1.18	1.06	1.02	0.97	1.03	1.01	0.81	1.00	0.99
43	2.34	1.09	1.08	1.88	1.06	1.06	1.52	1.02	1.04	1.24	0.99	1.02	1.03	0.96	1.00	0.85	0.93	0.99
49	2.49	1.03	1.09	1.99	0.99	1.07	1.61	0.96	1.05	1.32	0.93	1.03	1.09	0.90	1.01	0.90	0.87	0.99
54	2.66	0.97	1.12	2.13	0.94	1.10	1.72	0.90	1.07	1.40	0.87	1.05	1.16	0.85	1.03	0.96	0.82	1.01
60	2.87	0.93	1.16	2.29	0.90	1.13	1.85	0.86	1.11	1.50	0.83	1.08	1.24	0.81	1.06	1.03	0.78	1.04
66	3.13	0.91	1.21	2.49	0.87	1.18	2.01	0.84	1.15	1.63	0.81	1.12	1.34	0.78	1.10	1.11	0.75	1.08
71	3.46	0.89	1.29	2.74	0.85	1.26	2.21	0.82	1.22	1.79	0.78	1.19	1.47	0.76	1.16	1.21	0.73	1.13

Legend
 S Suction
 HG Hot gas
 L Liquid

Table 2 - Minimum capacity for oil entrainment in the discharge piping (kW) for R-407C copper tube, 30RWA

Saturated condensing temperature, °C	Outside pipe diameter, inch											
	1/2	5/8	3/4	7/8	1-1/8	1-3/8	1-5/8	2-1/8	2-5/8	3-1/8	3-5/8	4-1/8
27	0.81	1.48	2.39	3.66	7.14	12.06	18.64	37.21	63.94	99.81	145.60	201.98
32	0.84	1.51	2.46	3.76	7.28	12.34	19.06	38.09	65.42	102.13	148.94	206.66
38	0.84	1.51	2.50	3.80	7.42	12.56	19.41	38.76	66.61	103.96	151.62	210.35
43	0.88	1.55	2.53	3.87	7.53	12.73	19.66	39.25	67.42	105.23	153.48	212.92
49	0.88	1.55	2.53	3.87	7.56	12.80	19.77	39.50	67.84	105.90	154.43	214.26
54	0.88	1.55	2.53	3.87	7.56	12.80	19.77	39.46	67.81	105.86	154.40	214.19
60	0.84	1.55	2.53	3.87	7.49	12.70	19.62	39.18	67.32	105.05	153.24	212.60
66	0.84	1.51	2.46	3.80	7.39	12.45	19.27	38.44	66.08	103.12	150.42	208.66
71	0.81	1.48	2.43	3.69	7.17	12.17	18.78	37.49	64.43	100.55	146.69	203.49

Table 3 - R-407C correction factors for oil entrainment in the discharge piping

Saturated suction temperature, °C							
-23	-18	-12	-7	-1	4	10	
0.86	0.89	0.92	0.94	0.97	1	1.03	

See chapter "Discharge pipe sizing"

Discharge piping

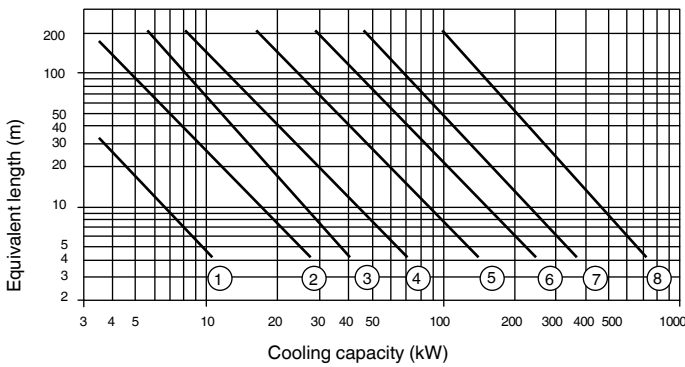

Legend
 1 1/2"
 2 3/8"
 3 3/4"
 4 7/8"
 5 1-1/8"
 6 1-3/8"
 7 1-5/8"
 8 2-1/8"

Liquid piping

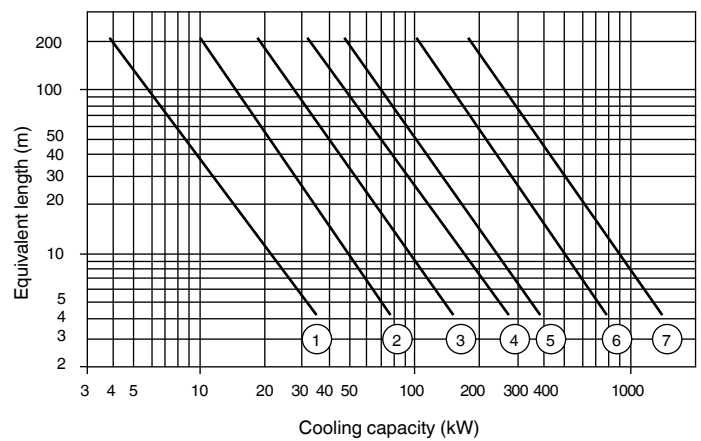

Legend
 1 3/8"
 2 1/2"
 3 5/8"
 4 3/4"
 5 7/8"
 6 1-1/8"
 7 1-3/8"

9 - NOMINAL EVAPORATOR WATER FLOW CONTROL

The water circulation pumps of the 30RW/RWA units have been sized to allow the hydronic modules to cover all possible configurations based on the specific installation conditions, i.e. for various temperature differences between the entering and the leaving water (ΔT) at full load, which can vary between 3 and 10 K.

This required difference between the entering and leaving water temperature determines the nominal system flow rate. It is above all absolutely necessary to know the nominal system flow rate to allow its control via a manual valve provided in the water leaving piping of the module (item 9 in the typical hydronic circuit diagram).

With the pressure loss generated by the control valve in the hydronic system, the valve is able to impose the system pressure/flow curve on the pump pressure/flow curve, to obtain the desired operating point (see example).

The pressure drop reading in the plate heat exchanger is used to control and adjust the nominal system flow rate. The pressure drop is measured with the pressure gauge connected to the heat exchanger water inlet and outlet.

Use this specification for the unit selection to know the system operating conditions and to deduce the nominal air flow as well as the plate heat exchanger pressure drop at the specified conditions. If this information is not available at the system start-up, contact the technical service department responsible for the installation to get it.

These characteristics can be obtained from the technical literature using the unit performance tables for a ΔT of 5 K at the evaporator or with the Electronic Catalogue selection program for all ΔT conditions other than 5 K in the range of 3 to 10 K.

9.1 - Water flow control procedure

As the total system pressure drop is not known exactly at the start-up, the water flow rate must be adjusted with the control valve provided to obtain the specific flow rate for this application.

Proceed as follows:

Open the valve fully (approximately 9 turns counter-clockwise).

Start-up the pump using the forced start command (refer to the controls manual) and let the pump run for two consecutive hours to clean the hydronic circuit of the system (presence of solid contaminants).

Read the plate heat exchanger pressure drop by taking the difference of the readings of the pressure gauge connected to the plate heat exchanger inlet and outlet, using valves (see diagrams below), and comparing this value after two hours of operation.

Entering water pressure reading

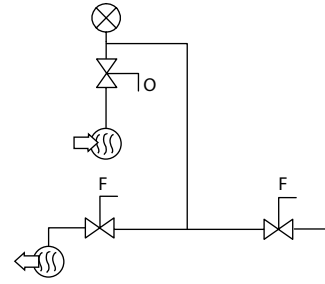

Leaving water pressure reading

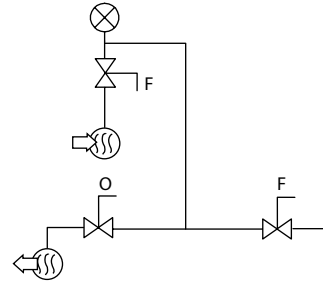

Legend

O	Open
F	Closed
	Water inlet
	Water outlet
	Pressure gauge

If the pressure drop has increased, this indicates that the screen filter must be removed and cleaned, as the hydronic circuit contains solid particles. In this case close the shutoff valves at the water inlet and outlet and remove the screen filter after emptying the hydronic section of the unit.

Renew, if necessary, to ensure that the filter is not contaminated.

When the circuit is cleaned, read the pressures at the pressure gauge (entering water pressure - leaving water pressure), expressed in bar and convert this value to kPa (multiply by 100) to find out the plate heat exchanger pressure drop.

Compare the value obtained with the theoretical selection value. If the pressure drop measured is higher than the value specified this means that the flow rate in the plate heat exchanger (and thus in the system) is too high. The pump supplies an excessive flow rate based on the global pressure drop of the application. In this case close the control valve one turn and read the new pressure difference.

Proceed by successively closing the control valve until you obtain the specific pressure drop that corresponds to the nominal flow rate at the required unit operating point.

- If the system has an excessive pressure drop in relation to the available static pressure provided by the pump, the resulting water flow rate will be reduced and the difference between entering and leaving water temperature of the hydronic module will be increased.

To reduce the hydronic system pressure drops, it is necessary:

- to reduce the individual pressure drops as much as possible (bends, level changes, accessories, etc.)
- to use a correctly sized piping diameter.
- to avoid hydronic system extensions, wherever possible.

Example: Unit with a given nominal flow rate of 4.8 l/s

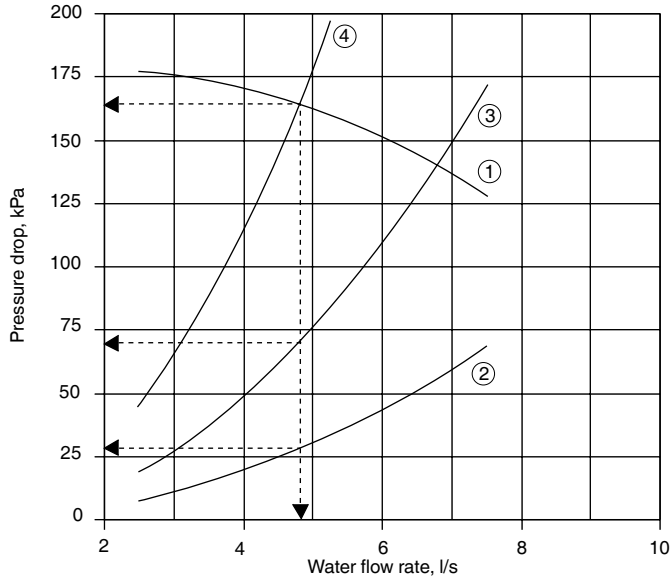

Legend

- 1 Unit pump curve
- 2 Plate heat exchanger pressure drop (to be measured with the pressure gauge installed at the water inlet and outlet)
- 3 Installation pressure drop with control valve wide open
- 4 Installation pressure drop after valve control to obtain the specified flow rate

9.2 - Evaporator pump flow/pressure curve

Single pumps

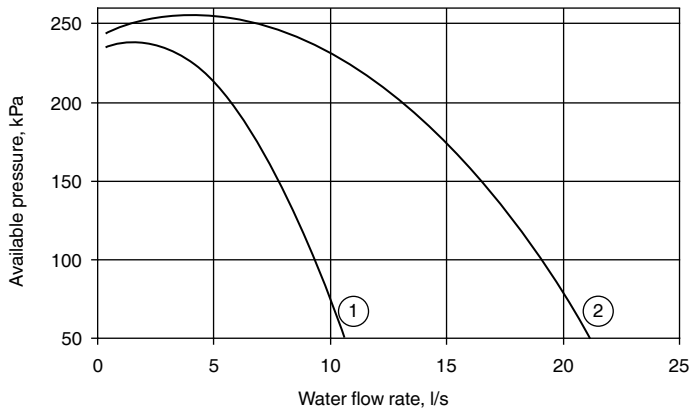

Legend

- 1 RWA 110-150
- 2 30RW/RWA 160-300

Dual pumps

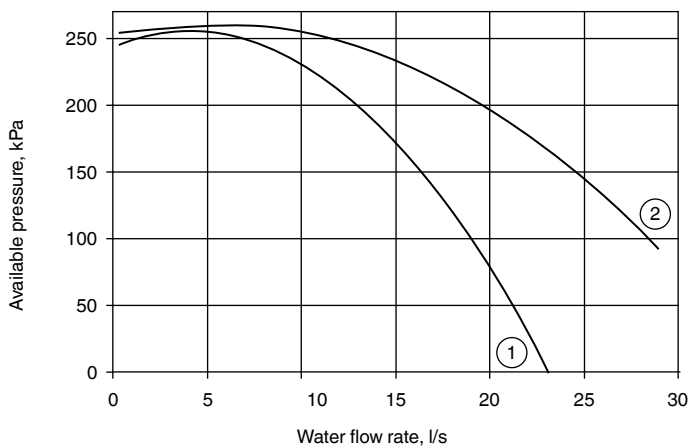

Legend

- 1 RWA 110-185
- 2 30RW-RWA 210-300

9.3 - Available static system pressure (evaporator side)

Single pump

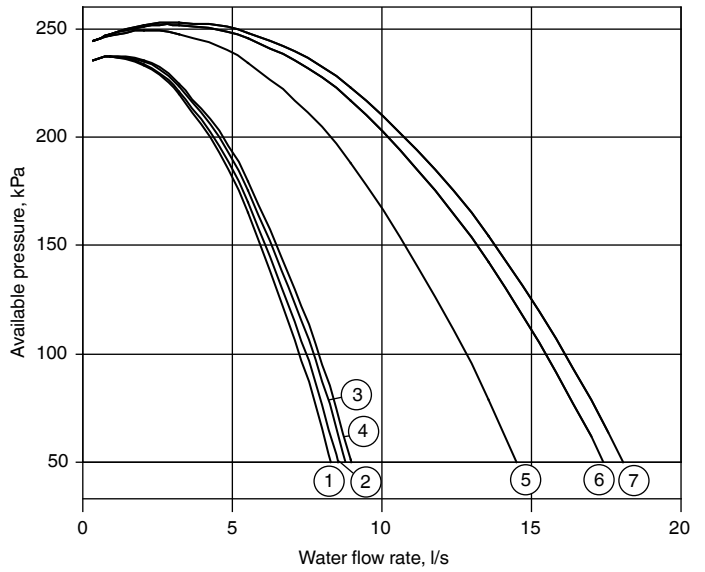

Legend

- 1 RWA 110
- 2 RWA 120
- 3 RWA 135
- 4 RWA 150
- 5 RWA 160-185
- 6 30RW/RWA 210-245
- 7 30RW/RWA 275-300

Dual pumps

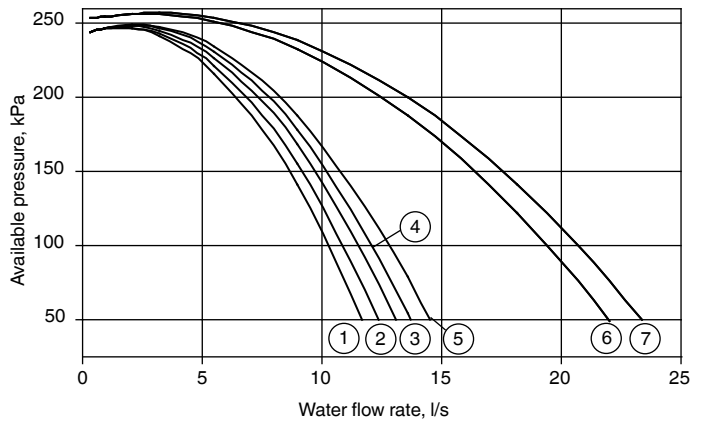

Legend

- 1 RWA 110
- 2 RWA 120
- 3 RWA 135
- 4 RWA 150
- 5 RWA 160-185
- 6 30RW/RWA 210-245
- 7 30RW/RWA 275-300

10 - CONDENSER WATER FLOW RATE

The 30RW units with hydronic module are equipped with a variable-speed water pump, automatically adjusting the flow rate to maintain the lowest condensing pressure possible. No control is necessary at the start-up.

10.1 - Condenser pump flow/pressure curve

Single pumps

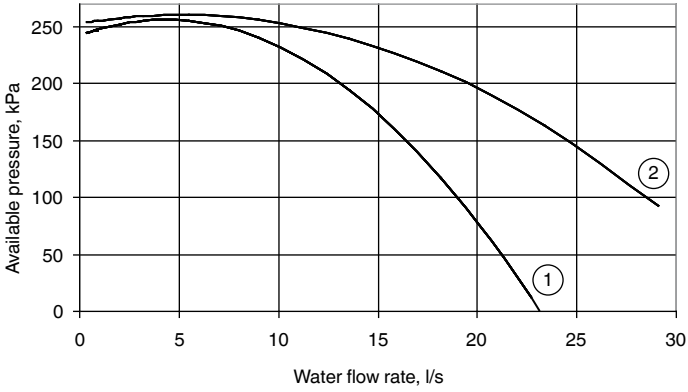

Legend

- 1 RWA 110-185
- 2 30RW-RWA 210-300

Dual pumps

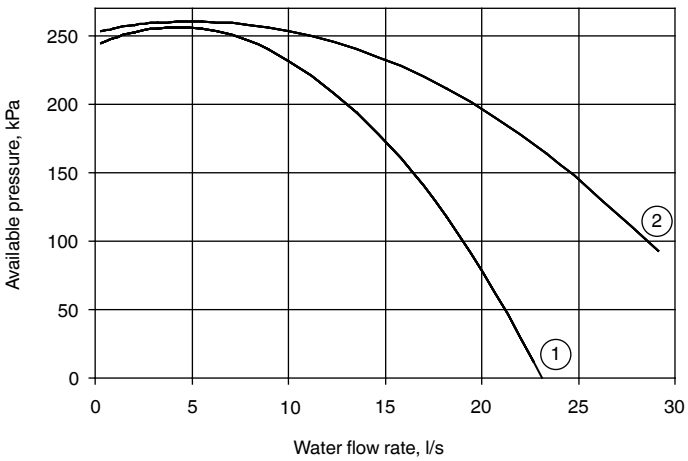

Legend

- 1 RWA 110-185
- 2 30RW-RWA 210-300

10.2 - Available static system pressure (condenser side)

Single pump

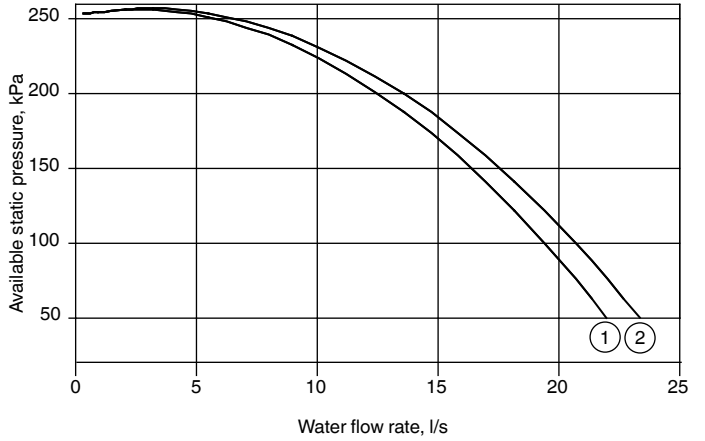

Legend

- 1 30RW 210-245
- 2 30RW 275-300

Dual pumps

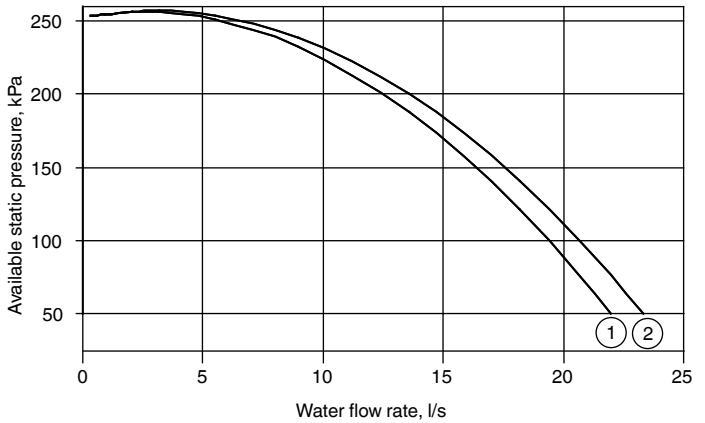

Legend

- 1 30RW 210-245
- 2 30RW 275-300

11 - 30RW UNIT OPERATION WITH A DRYCOOLER

11.1 - Operating principle

The 30RW units have been specially designed to optimise the operation of systems, using drycoolers as heat rejection system.

With a variable-speed condenser water pump integrated into the 30RW, the complexity of traditional systems, using a three-way valve has been eliminated.

The installation of an operational system is limited on the condensing water loop side to connecting the drycooler entering and leaving water piping to the 30RW unit.

The Pro-Dialog Plus control of the 30RW includes algorithms to permit constant automatic optimisation:

- drycooler fan stage operation
- water flow rate variation in the loop between the condenser and the drycooler.

Parallel control of the fan stages (up to 8 stages maximum) and of the variable water flow rate of the loop permit year-round system operation down to -20°C outside temperature without any additional control.

11.2 - Auxiliary electronic analogue input and output board (AUX1) for control of the drycooler

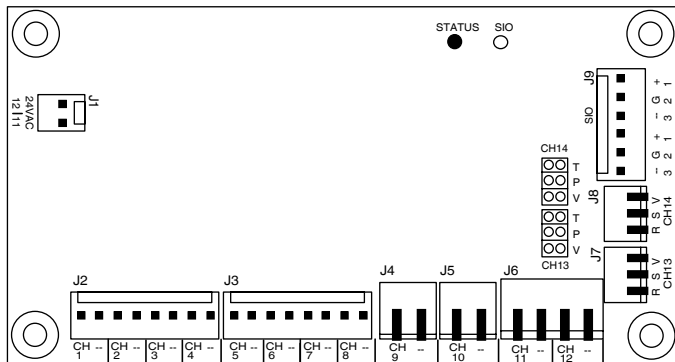

- Connector J2: Discrete outputs CH 1 to 4 for fan stages 1 to 4.
- Connector J3: Discrete outputs CH 5 to 8 for fan stages 5 to 8.
- Connectors J4 and J5: Analogue outputs 0-10 V dc not used on the drycoolers (only used for fan speed variation of the air-cooled condensers).
- Connector J6: Analogue inputs CH 11 and 12 for ambient temperature and drycooler leaving water temperature.
- Connector J9: Communication bus with NRCP master board of the 30RW unit.

The electronic board specifically integrated in the control box of the drycooler and a communication bus connected to the microprocessor board of the 30RW are used for the overall system control.

Pro-Dialog Plus optimises system operation to obtain the best efficiency with variation of the water flow rate and the number of fans required for any thermal load and outside temperature conditions.

The electronic board (AUX1) integrated in the control box of the drycooler has analogue inputs for outside air temperature and drycooler leaving water temperature sensors, as well as eight discrete outputs permitting control of up to eight fan stages.

11.3 - Configuration of the number of fan stages and the automatic changeover of the fan stages

Please refer to the instructions in the Pro-Dialog Plus IOM for the configuration of the number of fan stages to be controlled. It is enough to enter the number of fan stages of the drycooler in the Pro-Dialog Plus service menu. The number of discrete outputs controlling the fans are activated by the control.

Pro-Dialog Plus controls the automatic changeover of all fan stages, based on the operating time and the number of start-ups of the different stages. This function is used to prevent that fan motors only operate a little or not at all and that their shafts seize up, especially during periods when the demand for cooling is low and when the outside temperature is low. This changeover is often specified by the drycooler manufacturers to ensure the long operating life of the fan motors that are only little or not at all used in these particular operating conditions.

11.4 - Fan stage assignment

The minimum configuration of the number of fan stages is 2 for correct operation.

Depending on the drycooler capacity the number of fans can be between 2 and 8. They can be controlled by one fan or by linked pairs, if necessary.

A drycooler with 4 or 6 fans installed in series for example along the length of the unit will result in a configuration of 4 or 6 fan stages.

Reciprocally a drycooler with 8 or 12 fans arranged in pairs along the length of the unit will also result in a configuration of 4 or 6 fan stages.

Configuration with 4 and 6 stages (min. 2 - max. 8)

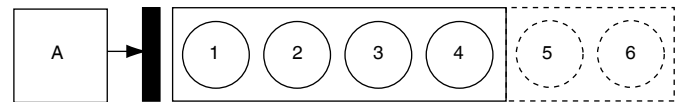

Fans linked in pairs -
4 and 6-stage configuration (min. 2 - max. 8)

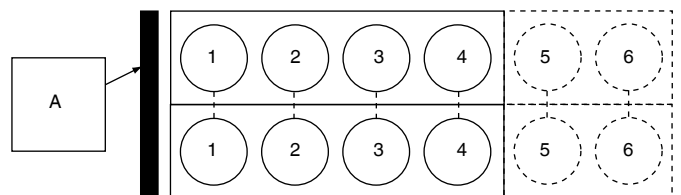

Legend

A Entering and leaving water manifold side
1 to 6 fans

11.5 - 30RW units without evaporator and condenser pump, three-way valve configuration for low outside temperature application

30RW units can be supplied from the factory without evaporator and condenser pump. If year-round low-temperature operation is planned, the chiller will be installed with a three-way valve that is not supplied with the chiller.

In this case Pro-Dialog Plus should be configured for three-way valve system control from an analogue 0-10 volt output on the NRCP type master board. An adequate condensing temperature will be maintained with constant condenser flow rate. This configuration permits year-round system operation down to -20°C outside temperature.

Control and changeover of the fan stages are described in the paragraph “Configuration of the number of fan stages and automatic changeover of the fan stages” is identical in this case.

11.6 - Drycooler installation

For the drycooler installation follow professional guidelines.

- Water pipe sizing
- Maximum piping and shut-off valve pressure drops based on the available pressure of the 30RW pumps
- Maximum drycooler elevation in relation to the chiller (safety valve at 4 bar on the 30RW water circuit).
- Fan stage control (see “Fan stage control”).
- Good positioning of the outside air temperature and drycooler leaving water temperature sensors.

12 - 30RWA UNIT OPERATION WITH REMOTE AIR-COOLED CONDENSER

12.1 - Operating principle

30RWA units are specially designed to optimise the operation of split installations using air-cooled condensers as the chiller heat rejection system. The installation of an operational system is limited to the connection of the air-cooled condenser entering and leaving piping to the 30RWA unit.

The Pro-Dialog Plus control system of the 30RWA units incorporates the logic to permit control of the different fan versions (single-circuit, dual-circuit, fixed and variable-speed fan, separate ventilation or interlaced ventilation at the circuit level).

12.2 - Master fan

The physical position of the air-cooled single- or dual-circuit air-cooled condenser with fixed or variable-speed fans depends on the position of the leaving liquid refrigerant manifold. In all cases there is always a so-called master fan. This is the fixed or variable-speed fan that is physically the closest to the leaving liquid refrigerant manifold.

This ensures optimum subcooling on the leaving condenser side, especially at part load. This is the first fan to start in each circuit and the last fan to stop. A fan configuration with fixed-speed fans permits year-round system operation down to 0°C outside temperature.

A fan configuration with a variable-speed master fan permits year-round operation down to -10°C outside temperature.

12.3 - Dual-circuit condenser with separate ventilation and interlaced ventilation

For dual-circuit air-cooled condensers the most frequent and recommended configuration is with an air-cooled condenser with completely independent circuits at fan level. This configuration is called “separate ventilation” by circuit.

It is also possible to control ventilation of a dual-circuit air-cooled condenser where the fans are not independent by circuit. This is called “interlaced ventilation”

The Pro-Dialog Plus service configuration of the fans permits setting up these two dual-circuit air-cooled condenser types.

12.4 - Auxiliary electronic analogue input and output and discrete output board (AUX1) for control of the air-cooled remote condenser

This is the same board as the one used in the drycoolers (see paragraph “Auxiliary electronic analogue input and output and discrete output board for control of the drycooler”).

Refer to the assignment of the discrete output of the board based on the air-cooled condenser type installed (single-circuit, dual-circuit with separate ventilation, dual-circuit with interlaced ventilation).

See paragraph “Possible fan arrangements based on the air-cooled condenser type used in the installation”

- 0-10 V dc analogue outputs connectors J4 and J5: Used for master fan speed variation of circuits A and B of the air-cooled condensers for operation at low outside temperature.
- Connector J6: Analogue inputs CH 11 for outside temperature sensors
- Connector J9: Communication with the master basic board of the 30RW unit.

12.5 - Configuration of the number of fan stages and fan type based on the air-cooled condenser model used in the installation

Please refer to the instructions in the Pro-Dialog Plus IOM for the 30RW/30RWA units to carry out the parameter setting of the air-cooled condenser used in the installation:

- Single-circuit or dual-circuit condenser
- Use of speed variation on the master fan(s)
- Dual-circuit condenser with separate or interlaced ventilation
- Number of fixed-speed fans

Based on the parameter setting used, the arrangement of the discrete and corresponding analogue outputs controlling the fans will be activated by the control.

The minimum configuration of the number of fan stages is 2 for correct operation (2 fixed-speed or 1 variable-speed + 1 fixed-speed fan).

12.6 - Possible fan arrangements based on the air-cooled condenser type used in the installation

Single-circuit condenser

Circuit	Possible fan arrangements									
A	<table border="1"> <tr> <td>①</td> <td>②</td> <td>③</td> </tr> </table> Minimum configuration 30RWA 110-150	①	②	③						
①	②	③								
A	<table border="1"> <tr> <td>①</td> <td>②</td> <td>③</td> <td>④</td> </tr> </table>	①	②	③	④					
①	②	③	④							
A	<table border="1"> <tr> <td>①</td> <td>②</td> <td>③</td> <td>④</td> <td>⑤</td> </tr> </table>	①	②	③	④	⑤				
①	②	③	④	⑤						
A	<table border="1"> <tr> <td>①</td> <td>②</td> <td>③</td> <td>④</td> <td>⑤</td> <td>⑥</td> </tr> </table>	①	②	③	④	⑤	⑥			
①	②	③	④	⑤	⑥					
A	<table border="1"> <tr> <td>①</td> <td>②</td> <td>③</td> <td>④</td> <td>⑤</td> <td>⑥</td> <td>⑦</td> </tr> </table>	①	②	③	④	⑤	⑥	⑦		
①	②	③	④	⑤	⑥	⑦				
A	<table border="1"> <tr> <td>①</td> <td>②</td> <td>③</td> <td>④</td> <td>⑤</td> <td>⑥</td> <td>⑦</td> <td>⑧</td> </tr> </table>	①	②	③	④	⑤	⑥	⑦	⑧	
①	②	③	④	⑤	⑥	⑦	⑧			
A	<table border="1"> <tr> <td>①</td> <td>②</td> <td>③</td> <td>④</td> <td>⑤</td> <td>⑥</td> <td>⑦</td> <td>⑧</td> <td>⑨</td> </tr> </table>	①	②	③	④	⑤	⑥	⑦	⑧	⑨
①	②	③	④	⑤	⑥	⑦	⑧	⑨		

Notes

① Is the head fan that can be fixed or variable speed

If fan ① has variable speed, the outputs assigned to board AUX1 are CH1 to CH8 from fan ②.

If fan ① has fixed speed, the outputs assigned to board AUX1 are CH1 to CH8 from fan ①.

Dual-circuit condenser with separate ventilation

Circuit	Possible fan arrangements					
A	<table border="1"> <tr> <td>①</td> <td>②</td> </tr> </table>	①	②			
①	②					
B	<table border="1"> <tr> <td>①</td> <td>②</td> </tr> </table>	①	②			
①	②					
A	<table border="1"> <tr> <td>①</td> <td>②</td> <td>③</td> </tr> </table>	①	②	③		
①	②	③				
B	<table border="1"> <tr> <td>①</td> <td>②</td> <td>③</td> </tr> </table> Minimum configuration 30RWA 160-300	①	②	③		
①	②	③				
A	<table border="1"> <tr> <td>①</td> <td>②</td> <td>③</td> <td>④</td> </tr> </table>	①	②	③	④	
①	②	③	④			
B	<table border="1"> <tr> <td>①</td> <td>②</td> <td>③</td> <td>④</td> </tr> </table>	①	②	③	④	
①	②	③	④			
A	<table border="1"> <tr> <td>①</td> <td>②</td> <td>③</td> <td>④</td> <td>⑤</td> </tr> </table>	①	②	③	④	⑤
①	②	③	④	⑤		
B	<table border="1"> <tr> <td>①</td> <td>②</td> <td>③</td> <td>④</td> <td>⑤</td> </tr> </table>	①	②	③	④	⑤
①	②	③	④	⑤		

Notes

① Is the head fan that can be fixed or variable speed for circuit A and B

If fan ① has variable speed, the outputs assigned to board AUX1 are CH1 to CH4 for circuit A and CH5 to CH8 for circuit B from fan ② of each circuit.

If fans ① has fixed speed, the outputs assigned to board AUX1 are CH1 to CH4 for circuit A and CH5 to CH8 for circuit B from fan ①.

Dual-circuit condenser with interlaced ventilation

Circuit	Possible fan arrangements
A+B	
A+B	Minimum configuration 30RWA 160-300
A+B	
A+B	
A+B	
A+B	
A+B	
A+B	

Notes

Is the head fan that can be fixed or variable speed for circuits A and B.

If fan has variable speed, the outputs assigned to board AUX1 are CH1 to CH8 from fan .

If fan has fixed speed, the outputs assigned to board AUX1 are CH1 to CH8 from fan .

Dual-circuit condenser with interlaced ventilation

Circuit	Possible fan arrangements
A+B	
B	
A+B	Minimum configuration 30RWA 160-300
B	
A+B	
B	
A+B	
B	
A+B	
B	
A+B	
B	

Notes

Is the head fan that can be fixed or variable speed for circuits A and B

If fan has variable speed, the outputs assigned to board AUX1 are CH1 to CH8 for circuits A and B from fan .

If fan has fixed speed, the outputs assigned to board AUX1 are CH1 to CH8 for circuits A and B from fan .

Legend

Head fan

Fans 1 to 9

13 - START-UP

13.1 - Preliminary checks

- Never be tempted to start the chiller without reading fully, and understanding, the operating instructions and without having carried out the following pre-start checks:
- Check the chilled water circulation pump operation with the Quick Test function.
- Check the air handling units and all other equipment connected to the evaporator. Refer to the manufacturer's instructions.
- Check the condensing loop water circulation pump operation with the Quick Test function.
- For units without hydronic module, the water pump overheat protection devices must be connected in series with the pump contactor power supply.
- Ensure that there are no refrigerant leaks.
- Confirm that all pipe securing bands are tight.
- Confirm the the electrical connections are secure.

13.2 - Actual start-up

IMPORTANT

- *Commissioning and start-up of the chiller must be supervised by a qualified refrigeration engineer.*
- *Start-up and operating tests must be carried out with a thermal load applied and water circulating in the evaporator.*
- *All set-point adjustments and control tests must be carried out before the unit is started up.*

The unit should be started up in Local ON mode.

For 30RWA units operating with a remote air-cooled condenser the compressor oil level must be monitored during the system start-up phase. This is to ensure that the oil charge of the original compressors is sufficient for the system size and the piping configuration. Once the oil level has stabilised, it must not be lower than 1/4 of the oil sight glass level. An additional oil quantity may be necessary for piping lengths (supply/return) exceeding 200 mm.

Ensure that all safety devices are operational, especially that the high pressure switches are switched on and that the alarms are acknowledged.

13.3 - Operation of two units in master/slave mode

The control of a master/slave assembly is in the entering water piping (system return) and does not require any additional sensors (standard configuration). For 30RW 160-300 units, it can also be located in the leaving water. In this case two additional sensors must be added on the common piping. All parameters, required for the master/slave function must be configured using the Service Configuration menu.

All remote controls of the master/slave assembly (start/stop, set point, load shedding etc.) are controlled by the unit configured as master and must only be applied to the master unit.

IMPORTANT: The two units must be equipped with option No. 155 - CCN time scheduling and communications "Clock Board?"

Depending on the installation and control type, each unit can control its own water pump. If there is only one common pump for the two units, the master unit can control this. In this case shut-off valves must be installed on each unit. They will be activated at the opening and closing by the control of each unit (and the valves will be controlled using the dedicated water pump outputs).

30RW/RWA 110 to 300 (standard configuration: return water control)

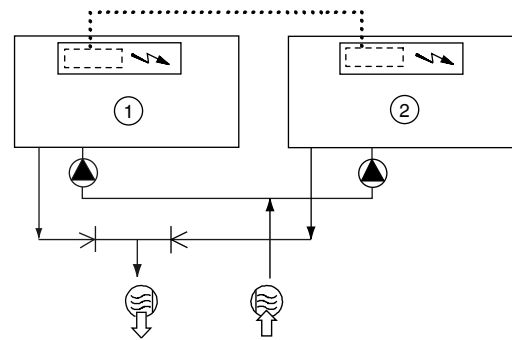

30RW/RWA 160 to 300 (with configuration: leaving water control)

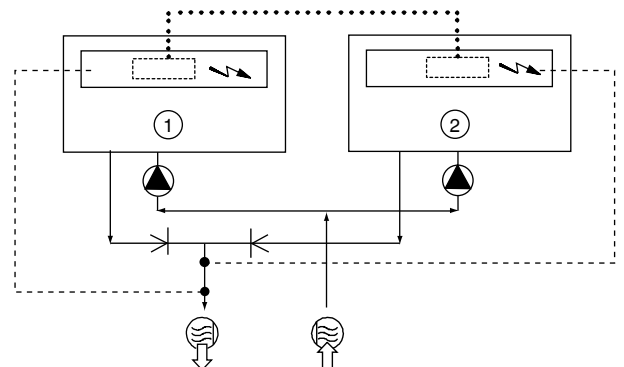

Legend

- 1 Master unit
- 2 Slave unit
- Additional CCN board (one per unit, with connection via communication bus)
- Control boxes of the master and slave units
- Water inlet
- Water outlet
- Water pumps for each unit (included as standard for units with hydronic module)
- Additional sensors for leaving water control, to be connected to channel 1 of the slave boards of each master and slave unit
- CCN communication bus
- Connection of two additional sensors

14 - MAJOR SYSTEM COMPONENTS AND OPERATION DATA

14.1 - Compressors

30RW/30RWA units use hermetic scroll compressors. The only refrigerant permitted for these compressors is R-407C.

30RWA split units operating with an air-cooled condenser, are supplied with the refrigerant circuit and consequently the compressor under nitrogen pressure between 0.3 and 1 bar.

The compressors are not certified for mobile applications or use in explosive environments.

IMPORTANT: All compressor and system pressure tests must be carried out by qualified personnel, taking the greatest care with potential dangers resulting from the pressures used, and respecting the maximum operating pressure limit on the high and low-pressure side, shown on the unit and compressor name plates.

- **Maximum operating pressure, low-pressure side for compressors DQ 12 CA 027 and DQ 12 CA 028: 20 bar**
- **Maximum operating pressure, low-pressure side for compressors DQ 12 CA 025 - DQ 12 CA 001 - DQ 12 CA 002 - DQ 12 CA 031 - DQ 12 CA 032: 25 bar**
- **Maximum operating pressure, high-pressure side for compressors DQ 12 CA 025 to DQ 12 CA 028: 32 bar.**

For certain units incorporating compressors with different maximum operating pressures on the low-pressure side in the same refrigerant circuit, the lowest maximum pressure should be taken into consideration.

Any modification or alteration such as soldering on the compressor shell may invalidate the right to use the equipment.

30RW/30RWA units using these compressors are installed in areas where the temperature must be between 5°C minimum and 40°C maximum. The temperature around the compressors must not exceed 50°C during unit shutdown cycles.

Shock absorbers are installed under the compressor feet. Tighten the rubber shock absorbers until there is contact between the flat washer and the steel bar.

Scroll compressors are unidirectional, and refrigerant compression is only ensured, when the phase order is followed. Compressors DQ 12 CA 025 to DQ 12 CA 032 incorporate reverse rotation protection. If reverse rotation is not corrected by reversing the phases, the compressor will cut out via the internal motor protection.

For compressors DQ 12 CA 027 and DQ 12 CA 028 a phase order control function is incorporated in the external motor protection module.

14.2 - Lubricant

The compressors have the following factory lubricant charge: polyolester oil (reference: MAN-7754024_EE).

This lubricant must not be mixed with any other type of lubricant.

When 30RWA units are connected to the remote air-cooled condenser, opening the circuit to the atmosphere must be minimised (less than half an hour). The connection of the discharge piping must be fast to prevent contamination of the lubricant with moisture.

Check that the oil level is between 1/4 and 3/4 in the sight glass before start-up and after normal unit operation.

If an additional oil quantity is required to compensate the initial low level in the compressors (due to the piping length between chiller and air-cooled condenser), top up the charge, using only the permitted lubricant shown on the compressor name plate: polyolester oil (ref: MAN-7754024_EE).

14.3 - Evaporators and condensers

The evaporators and condensers are plate heat exchangers. They are tested and stamped for a maximum operating pressure of 3200 kPa on the refrigerant side and 1000 kPa on the water side.

The heat exchanger sizing for the whole range ensures a saturated evaporating temperature of 5.5°C and a condensing temperature of around 45°C with actual subcooling of around 8 K at the condenser leaving side, based on nominal Eurovent conditions.

The evaporators and condensers are single-circuit for sizes 30RW/RWA 110 to 150 and interlaced dual-circuit for sizes 30RW 160 to 300.

The water connections between the heat exchangers and the piping of the hydronic modules have quick-connect Victaulic couplings to facilitate pump disassembly, if required.

The control thermistors can in some cases be included in the heat exchangers themselves. This depends on the heat exchanger type and the number of plates used.

A drain with a 1/4 turn valve is included in the leaving water of all heat exchangers.

The evaporators have 19 mm thick polyurethane foam thermal insulation. For option 150 (heat pump), the condensers also have 19 mm thick polyurethane foam thermal insulation.

The products that may be added for thermal insulation of the containers during the water piping connection procedure must be chemically neutral in relation to the materials and coatings to which they are applied. This is also the case for the products originally supplied by Carrier.

NOTES: Monitoring during operation, re-qualification, re-testing and re-testing dispensation:

- Follow the regulations on monitoring pressurised equipment.
- It is normally required that the user or operator sets up and maintains a monitoring and maintenance file.
- If there are no regulations or to complement them follow the control programmes of EN 378.
- If they exist follow local professional recommendations.
- Regularly inspect the condition of the coating (paint) to detect blistering resulting from corrosion. To do this, check a non-insulated section of the container or the rust formation at the insulation joints.
- Regularly check for possible presence of impurities (e.g. silicon grains) in the heat exchange fluids. These impurities may be the cause of the wear or corrosion by puncture.
- Filter the heat exchange fluid check and carry out internal inspections as described in EN 378-2, annex C.
- In case of re-testing take the possible maximum pressure difference of 25 bar into consideration.
- The reports of periodical checks by the user or operator must be included in the supervision and maintenance file.

Repair

Any repair or modification of the plate heat exchangers is forbidden.

Only the replacement of the complete heat exchanger by an original heat exchanger supplied by the manufacturer is permitted. The replacement must be carried out by a qualified technician.

- The heat exchanger replacement must be shown on the monitoring and maintenance file.

Recycling

The plate heat exchanger is 100% recyclable. After use it contains refrigerant vapours and oil residue.

Operating life

This unit is designed for:

- prolonged storage of 15 years under nitrogen charge with a temperature difference of 20 K per day.
- 900000 cycles (start-ups) with a maximum difference of 6 K between two neighbouring points in the container, based on 12 start-ups per hour over 15 years at a usage rate of 57%.

14.4 - Thermostatic expansion device

The expansion devices used are thermostatic hermetic monobloc devices for sizes 30RW/30RWA 020 to 070 and modular devices for sizes 30RW/30RWA 080 to 300. They are factory-set to maintain between 5 and 6 K superheat in all operating conditions any do not require any change in setting, including for operation at part load. All models have a charge (MOP) for the thermostatic assembly that permits the maximum evaporating pressure to protect the compressor.

14.5 - Refrigerant

30RW/30RWA units operate exclusively with R-407C.

14.6 - High-pressure switch

30RW/30RWA units are equipped with a manually reset safety pressure switch. Refer to the controls manual for the alarm acknowledgements.

14.7 - High and low-pressure side safety valves

30RW units are equipped with safety valves in accordance with the European directive 97/23/CE. These safety valves are calibrated and sized in accordance with the original high and low-pressure side equipment. The originally supplied safety valves for the 30RWA units are sized to protect the original equipment. To protect equipment that has been added on the high-pressure side, refer to the applicable regulations and standards to determine which protection accessories may be required.

14.8 - Moisture indicator

Located in the liquid line, permits control of the unit charge, as well as the presence of moisture in the circuit. Bubbles in the sight glass indicate an insufficient charge or the presence of non-condensibles. If moisture is present, the colour of the indicator paper in the sight glass changes.

14.9 - Filter drier in the refrigerant circuit

The filter keeps the circuit clean and moisture-free. The moisture indicator shows when it is necessary to change the filter cartridges. A temperature difference between the filter drier inlet and outlet indicates a contamination of the cartridges.

14.10 - Fixed-speed cold water loop pump (evaporator side)

This pump is factory-installed as standard to guarantee the nominal flow in the chilled water loop.

This is a fixed-speed pump with available system pressure. See the pump flow/pressure curve.

The nominal system flow rate must be adjusted with the manual control valve, located on the leaving water piping (see chapter on the control of the nominal system pressure).

The maximum permitted concentration of the glycol additives is 35%.

The maximum pump suction pressure is limited to 4 bar due to the valve installed on the entering water piping.

14.11 - Variable-speed hot water loop pump (condenser side)

This pump is factory-installed as standard. It is a variable-speed pump with available system pressure. See the pump flow/pressure curve.

The system flow rate is automatically adjusted via the frequency converter built into the pump, based on the heat rejection load on the drycooler.

The maximum permitted concentration of the glycol additives is 35%.

The maximum pump suction pressure is limited to 4 bar due to the valve installed on the entering water piping.

14.12 - Evaporator and condenser pump suction filter

All evaporator and condenser pumps are protected by a suction filter. This is easily removable to recover solid particles, as it is fixed between two Victaulic couplings. It protects the plate heat exchanger pump against solid particles with a size exceeding 1,2 mm. Before the unit start-up it is important to turn the evaporator and condenser pump to decontaminate the water loops of any solid pollution.

A specific pump start-up function in the Quick Test menu is available for this task.

15 - MAINTENANCE

During the unit operating life the service checks and tests must be carried out in accordance with applicable national regulations.

If there are no similar criteria in local regulations, the information on checks during operation in annex C of standard EN 378-2 can be used.

External visual checks: annex A and B of standard EN378-2.

Corrosion checks: annex D of standard EN 378-2. These controls must be carried out:

- After an intervention that is likely to affect the resistance or a change in use or change of high-pressure refrigerant, or after a shut down of more than two years. Components that do not comply, must be changed. Test pressures above the respective component design pressure must not be applied (annex B and D).
- After repair or significant modifications or significant system or component extension (annex B).
- After re-installation at another site (annexes A, B and D).
- After repair following a refrigerant leak (annex D). The frequency of refrigerant leak detection can vary from once per year for systems with less than 1% leak rate per year to once a day for systems with a leak rate of 35% per year or more. The frequency is in proportion with the leak rate.

NOTE: High leak rates are not acceptable. The necessary steps must be taken to eliminate any leak detected.

NOTE 2: Fixed refrigerant detectors are not leak detectors, as they cannot locate the leak.

15.1 - Soldering and welding

Component, piping and connection soldering and welding operations must be carried out using the correct procedures and by qualified operators. Pressurised containers must not be subjected to shocks, nor to large temperature variations during maintenance and repair operations.

Any technician attending the machine for any purpose must be fully qualified to work on refrigerant and electrical circuits.

WARNING: Before doing any work on the machine ensure that the power is switched off. If a refrigerant circuit is opened, it must be evacuated, recharged and tested for leaks. Before any operation on a refrigerant circuit, it is necessary to remove the complete refrigerant charge from the unit with a refrigerant charge recovery unit.

All removal and refrigerant draining operations must be carried out by a qualified technician and with the correct material for the unit. Any inappropriate handling can lead to uncontrolled fluid or pressure leaks.

If an oil draining or recovery operation becomes necessary, the fluid transfer must be made using mobile containers.

15.2 - General unit maintenance

- Keep the unit itself and the space around it clean and free of obstructions. Remove all rubbish such as packing materials, as soon as the installation is completed.
- Regularly clean the exposed pipework to remove all dust and dirt. This makes detection of water leaks easier, and they can be repaired before more serious faults develop.
- Confirm that all screwed and bolted connections and joints are secure.
- Secure connections prevent leaks and vibration from developing.
- Check that all foam insulation joints on the heat exchanger piping are in good condition.

15.3 - Refrigerant charge

15.3.1 - Undercharge

If there is not enough refrigerant in the system, this is indicated by gas bubbles in the moisture sight glass.

If the undercharge is significant, large bubbles appear in the moisture sight glass, and the suction pressure drops. The compressor suction superheat is also high. The machine must be recharged after the leak has been repaired.

Find the leak and completely drain the system with a refrigerant recovery unit. Carry out the repair, leak test and then recharge the system.

IMPORTANT: After the leak has been repaired, the circuit must be tested, without exceeding the maximum low-side operating pressure shown on the unit name plate.

The refrigerant must always be recharged in the liquid phase into the liquid line. The refrigerant cylinder must always contain at least 10% of its initial charge. For the refrigerant quantity per circuit, refer to the data on the unit name plate.

15.3.2 - Verification of the charge

CAUTION: The 30RW units are supplied with a precise refrigerant charge (see Physical Data table).

To verify the correct system charge proceed as follows:
Ensure that no bubbles appear in the sight-glass, when operating the unit at full load for a while. Use a saturated condensing temperature between 45 and 50°C. Under these conditions the apparent subcooling which is equal to the saturated condensing temperature (1 - on the saturated dew point curve) minus the liquid refrigerant temperature (3) ahead of the expansion device must be between 12 and 14°C. This corresponds to an actual subcooling temperature of between 6 and 8 K at the condenser outlet, depending on the unit type. Actual subcooling is equal the saturated liquid temperature (2 - on the saturated bubble point curve) minus the liquid refrigerant temperature (3) ahead of the expansion device. Use the pressure tap supplied on the liquid piping to charge refrigerant and to find out the pressure of the liquid refrigerant. If the subcooling value is not correct, i.e. lower than the specified values, a leak detection test must be carried out on the unit, as it no longer contains its original charge.

WARNING: To ensure proper operation of 30RW units there must be at least 12 K of subcooling as the liquid refrigerant enters the expansion valve.

The 30RW units use refrigerant. For your information, we are reproducing here some extracts from the official publication dealing with the design, installation, operation and maintenance of air conditioning and refrigeration systems and the training of people involved in these activities, agreed by the air conditioning and refrigeration industry.

Apparent and actual subcooling

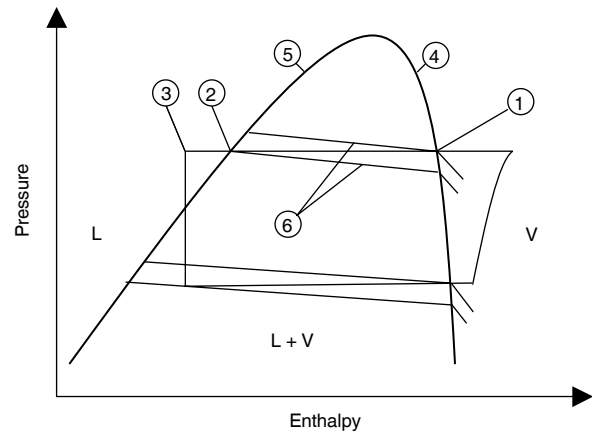

Legend

- 1 Saturated condensing temperature at the dew point
- 2 Saturated liquid temperature at the bubble point
- 3 Liquid refrigerant temperature
- 4 Saturation curve at the dew point
- 5 Saturation curve at the bubble point
- 6 Isotherms
- 7 Apparent subcooling (1 - 3)
- 8 Real subcooling (2 - 3)
- L Liquid
- L + V Liquid + vapour
- V Vapour

15.4 - Refrigerant guidelines

Refrigeration installations must be inspected and maintained regularly and rigorously by specialists. Their activities must be overseen and checked by properly trained people. To minimise discharge to the atmosphere, refrigerants and lubricating oil must be transferred using methods which reduce leaks and losses to a minimum.

- Leaks must be repaired immediately.
- If the residual pressure is too low to make the transfer alone, a purpose-built refrigerant recovery unit must be used.
- Compressor lubricating oil contains refrigerant. Any oil drained from a system during maintenance must therefore be handled and stored accordingly.
- Refrigerant under pressure must never be discharged to the atmosphere.

15.5 - Leak detection

Never use oxygen or dry air, as this would cause a risk of fire or explosion.

- Carry out a leak detection test on the whole system using the following methods: pressure test using dehydrated nitrogen or a mixture of nitrogen and refrigerant used for the system, helium leak test.
- Connect the compressor to the system by opening the valves.
- The duration of the test must be sufficient to guarantee the absence of very small leaks in the circuit.
- Use specific tools, designed for leak detection.
- The low-pressure side test pressure must not exceed pressure P_s indicated on the compressor and unit name plates.
- If there is a leak, repair it and carry out the leak detection test again.

15.6 - Evacuation

To evacuate the system, observe the following recommendations:

Connect the vacuum pump to the high (HP) and low-pressure (LP) side for evacuation of the complete circuit.

All units are equipped with valves with 3/8" SAE connections on the suction and liquid lines, permitting the connection of large-diameter flexible pipes limiting the pressure drops for the evacuation.

1. The vacuum level achieved must be 0.67 mbar (500 μ m Hg).
2. Wait 30 minutes.
3. If the pressure increases rapidly, the system is not leak-tight. Localise and repair the leaks. Restart the evacuation procedure and repeat steps 1, 2 etc.
4. If the pressure increases slowly, this indicates that moisture is present inside the system. Break the vacuum with nitrogen and restart the evacuation procedure (steps 1, 2 etc.).
5. Repeat the evacuation procedure (steps 1, 2); a vacuum level of 0.67 mbar (500 μ m Hg) must be achieved and maintained for four hours.

This vacuum level must be measured at one of the system connections and not at the vacuum pump pressure gauge.

ATTENTION: Do not use a megohmmeter and do not place any stress on the compressor motor when the system has been evacuated. There is a risk of internal short circuits between the motor windings.

Do not use additives for leak detection. Do not use CFCs/HCFCs as tracer fluids for leak detection.

15.7 - Recharging liquid refrigerant

CAUTION: 30RW units are charged with liquid HFC-407C refrigerant.

This non-azeotropic refrigerant blend consists of 23% R-32, 25% of R-125 and 52% R-134a, and is characterised by the fact that at the time of the change in state the temperature of the liquid/vapour mixture is not constant, as with azeotropic refrigerants. All checks must be pressure tests, and the appropriate pressure/temperature ratio table must be used to determine the corresponding saturated temperatures (saturated bubble point curve or saturated dew point curve).

Leak detection is especially important for units charged with refrigerant R-407C. Depending on whether the leak occurs in the liquid or in the vapour phase, the proportion of the different components in the remaining liquid is not the same.

NOTE: Regularly carry out leak checks and immediately repair any leak found.

15.8 - Characteristics of R-407C

See the table on the next page.

Saturated bubble point temperatures (bubble point curve)

Saturated dew point temperatures (dew point curve)

15.9 - Electrical maintenance

When working on the unit comply with all safety precautions described in section 1.3.

It is strongly recommended to change the unit fuses every 15000 operating hours or every three years.

It is recommended to verify that all electrical connections are tight:

- after the unit has been received at the moment of installation and before the first start-up,
- one month after the first start-up, when the electrical components have reached their nominal operating temperatures,
- then regularly once a year.

Characteristics of R-407C

Bar (relative)	Saturated bubble point temp., °C	Saturated dew point temp., °C	Bar (relative)	Saturated bubble point temp., °C	Saturated dew point temp., °C	Bar (relative)	Saturated bubble point temp., °C	Saturated dew point temp., °C
1	-28,55	-21,72	10,5	23,74	29,35	20	47,81	52,55
1,25	-25,66	-18,88	10,75	24,54	30,12	20,25	48,32	53,04
1,5	-23,01	-16,29	11	25,32	30,87	20,5	48,83	53,53
1,75	-20,57	-13,88	11,25	26,09	31,62	20,75	49,34	54,01
2	-18,28	-11,65	11,5	26,85	32,35	21	49,84	54,49
2,25	-16,14	-9,55	11,75	27,6	33,08	21,25	50,34	54,96
2,5	-14,12	-7,57	12	28,34	33,79	21,5	50,83	55,43
2,75	-12,21	-5,7	12,25	29,06	34,5	21,75	51,32	55,9
3	-10,4	-3,93	12,5	29,78	35,19	22	51,8	56,36
3,25	-8,67	-2,23	12,75	30,49	35,87	22,25	52,28	56,82
3,5	-7,01	-0,61	13	31,18	36,55	22,5	52,76	57,28
3,75	-5,43	0,93	13,25	31,87	37,21	22,75	53,24	57,73
4	-3,9	2,42	13,5	32,55	37,87	23	53,71	58,18
4,25	-2,44	3,85	13,75	33,22	38,51	23,25	54,17	58,62
4,5	-1,02	5,23	14	33,89	39,16	23,5	54,64	59,07
4,75	0,34	6,57	14,25	34,54	39,79	23,75	55,1	59,5
5	1,66	7,86	14,5	35,19	40,41	24	55,55	59,94
5,25	2,94	9,11	14,75	35,83	41,03	24,25	56,01	60,37
5,5	4,19	10,33	15	36,46	41,64	24,5	56,46	60,8
5,75	5,4	11,5	15,25	37,08	42,24	24,75	56,9	61,22
6	6,57	12,65	15,5	37,7	42,84	25	57,35	61,65
6,25	7,71	13,76	15,75	38,31	43,42	25,25	57,79	62,07
6,5	8,83	14,85	16	38,92	44,01	25,5	58,23	62,48
6,75	9,92	15,91	16,25	39,52	44,58	25,75	58,66	62,9
7	10,98	16,94	16,5	40,11	45,15	26	59,09	63,31
7,25	12,02	17,95	16,75	40,69	45,71	26,25	59,52	63,71
7,5	13,03	18,94	17	41,27	46,27	26,5	59,95	64,12
7,75	14,02	19,9	17,25	41,85	46,82	26,75	60,37	64,52
8	14,99	20,85	17,5	42,41	47,37	27	60,79	64,92
8,25	15,94	21,77	17,75	42,98	47,91	27,25	61,21	65,31
8,5	16,88	22,68	18	43,53	48,44	27,5	61,63	65,71
8,75	17,79	23,57	18,25	44,09	48,97	27,75	62,04	66,1
9	18,69	24,44	18,5	44,63	49,5	28	62,45	66,49
9,25	19,57	25,29	18,75	45,17	50,02	28,25	62,86	66,87
9,5	20,43	26,13	19	45,71	50,53	28,5	63,27	67,26
9,75	21,28	26,96	19,25	46,24	51,04	28,75	63,67	67,64
10	22,12	27,77	19,5	46,77	51,55	29	64,07	68,02
10,25	22,94	28,56	19,75	47,29	52,05	29,25	64,47	68,39

15.10 - Compressors

The compressors do not require any specific maintenance. Nevertheless the preventive system maintenance operations prevent specific compressor problems. The following periodic preventive maintenance checks are strongly recommended:

- Check the operating conditions (evaporating temperature, condensing temperature, discharge temperature, heat exchanger temperature difference, superheat, subcooling). These operating parameters must always be within the compressor operating range.
- Check that the safety devices are all operational and correctly controlled.
- Check oil level and quality. If there is a colour change in the sight glass, check the oil quality. This may include an acidity test, moisture control, a spectrometric analysis etc.
- Check the leak tightness of the refrigerant circuit.
- Check the compressor motor power input, as well as the voltage imbalance between phases.
- Check the tightening of all electrical connections.
- Ensure that the compressor is clean and runs correctly; verify that there is no rust on the compressor shell and no corrosion or oxydation at the electrical connections and the piping.

ATTENTION: *The compressor and piping surface temperatures can in certain cases exceed 100°C and cause burns. Particular caution is required during maintenance operations. At the same time, when the compressor is in operation, the surface temperatures can also be very cold (down to -15°C for units with a low leaving water temperature), and can cause frost burns.*

15.11 - Evaporator and condenser maintenance

There is no particular maintenance necessary on the plate heat exchanger. Check:

- that the insulating foam has not become detached or damaged during work on the units,
- that the entering and leaving water temperature sensors are well connected
- the cleanliness on the water heat exchanger side (no signs of leaks).
- that the periodic inspections required by local regulations have been carried out.

15.12 - Corrosion check

All metallic parts of the unit (chassis, casing panels, control boxes, heat exchangers etc.) are protected against corrosion by a coating of powder or liquid paint. To prevent the risk of blistering corrosion that can appear when moisture penetrates under the protective coatings, it is necessary to carry out periodic checks of the coating (paint) condition.

16 - AQUASNAP MAINTENANCE PROGRAM

All maintenance operations must be carried out by technicians who have been trained on Carrier products, observing all Carrier quality and safety standards.

16.1 - Maintenance schedule

Regular maintenance is indispensable to optimise equipment operating life and reliability. Maintenance operations must be carried out in accordance with the schedules below:

Service	Frequency
A	Weekly
B	Monthly
C	Annually
D	Special cases

If the equipment does not operate normally during maintenance operations, refer to the chapter on diagnostics and breakdowns of the '30RW/RWA Pro-Dialog Plus' controls manual).

IMPORTANT: Before each equipment maintenance operation please ensure that:

- **the unit is in the OFF position**
- **it is impossible for the unit to restart automatically during maintenance.**

16.2 - Description of the maintenance operations

The equipment is supplied with polyolester oil (POE). Use only Carrier-approved oil. On request Carrier can carry out an oil analysis of your installation.

Service A

Full-load operating test

Verify the following values:

- compressor high-pressure side discharge pressure
- compressor low-pressure side suction pressure
- charge visible in the sight glass
- temperature difference between the heat exchanger water entering and leaving temperature.

Verify the alarm status

Service B

Carrier out the operations listed under Service A.

Refrigerant circuit

- Full-load operating test. In addition to the operations described under Service A, check the following values:
 - compressor discharge pressure
 - compressor oil level
 - actual liquid subcooling
 - overheating at the expansion device
- Verify the charge status by checking the colour indicator of the sight glass. If the colour has turned to yellow, change the charge and replace the filter drier cartridges after carrying out a leak test of the circuit.

Electrical checks

- Check the tightening of the electric connections, contactors, disconnect switch and transformer.
- Check the status of the contactors and fuses.
- Carry out a quick test (refer to the '30RW/RWA Pro-Dialog Plus' controls manual).

Mechanical checks

- Verify the correct operation of the evaporator and condenser pumps with the Quick Test function.
- Verify the correct operation of cooling fans, speed converter and condensing pumps.

Water circuit checks

- Check the leak-tightness of the circuit.

Service C

Carry out the operations listed under Service B.

Refrigerant circuit

- Check the leak-tightness of the circuit and ensure that there is no piping damage.
- Carry out an oil contamination test. If acid, water or metallic particles are present, replace the oil in the circuit.
- Verify the tightening of the thermostatic mechanism of the expansion device.
- Full-load operating test. In addition to the checks carried out under Service B, validate the value between leaving water and the saturated evaporating temperature.
- Check the operation of the high-pressure switch(es). Replace them if there is a fault.
- Check the fouling of the filter drier (by checking the temperature difference in the copper piping). Replace it if necessary.

Electrical checks

- Check the status and insulation of the electrical cables.
- Check the phase/earth insulation of the compressors and pumps.
- Check the compressor and pump winding status.

Mechanical checks

- Check that no water has penetrated into the control box.
- Clean the filter of the air inlet grille and if necessary replace the filter.

Water circuit checks

- Clean the water filter.
- Purge the circuit with air.
- Verify the correct operation of the water flow switch.
- Check the status of the thermal piping insulation.
- Check the water flow by checking the heat exchanger pressure difference (using a pressure gauge).
- Check the concentration of the anti-freeze protection solution (ethylene glycol or polyethylene glycol).
- Check the heat transfer fluid status or the water quality.
- Check the steel pipe corrosion.

Service D

- Single pump and dual pump.
 - Mechanical seal: replace this every 13000 operating hours.
 - Bearing: replace this every 20000 operating hours.

17 - START-UP CKECKLIST FOR 30RW/RWA LIQUID CHILLERS (USE FOR JOB FILE)

Preliminary information

Job name:
Location:
Installing contractor:.....
Distributor:
Start-up preformed by:.....

Compressors

Model: Serial No.

Compressors

Circuit A

Circuit B

1. Model No. 1. Model No.....
Serial No.....
Serial No.....
Motor No.....
Motor No.....

2. Model No..... 2. Model No.....
Serial No..... Serial No.....
Motor No..... Motor No.....

Evaporator

Model No. Manufactured by
Serial No..... Date

Condensers

Model No. Manufactured by
Serial No..... Date

Additional air handling units and accessories

Preliminary equipment check

Is there any shipping damage ?
If so, where ?
Will this damage prevent unit start-up ?

- Unit is level in its installation
- Power supply agrees with the unit nameplate
- Electrical circuit wiring has been sized and installed properly
- Unit ground wire has been connected
- Electrical circuit protection has been sized and installed properly
- All terminals are tight
- All cables and thermistors have been inspected for crossed wires
- All plug assemblies are tight

Check air handling systems

- All air handlers are operating
- All chilled water valves are open
- All fluid piping is connected properly
- All air has been vented from the system
- Chilled water pump (CWP) is operating with the correct rotation. CWP amperage: Rated: Actual.....

Unit start-up

- CWP starter has been properly interlocked with the chiller
- Oil heaters have been energized for at least 24 hours (30RWA)
- Oil level is correct
- All discharge and liquid valves are open
- Unit has been leak checked (including fittings)
Locate, repair, and report any refrigerant leaks

.....

Check voltage imbalance: AB AC..... BC.....
 Average voltage = (see installation instructions)
 Maximum deviation = (see installation instructions)
 Voltage imbalance = (see installation instructions)

- Voltage imbalance is less than 2%

WARNING: Do not start chiller if voltage imbalance is greater than 2%. Contact local power company for assistance.

- All incoming power voltage is within rated voltage range

Check cooler water loop

Water loop volume = (litres)
 Calculated volume = (litres)
 2.5 liters/nominal kW capacity for air conditioning (units 30RW/30RWA 110-300)

- Proper loop volume established
- Proper loop corrosion inhibitor included litres of
- Proper loop freeze protection included (if required)..... litres of.....
- Piping includes electric heater tape, if exposed to the outside
- Inlet piping to cooler includes a 20 mesh strainer with a mesh size of 1.2 mm (unit without pump)

Check pressure drop across the evaporator

Entering evaporator = (kPa)
 Leaving evaporator = (kPa)
 (Leaving - entering) = (kPa)

WARNING: Plot cooler pressure drop on performance data chart (in product data literature) to determine total liters per second (l/s) and find unit's minimum flow rate.

Total l/s =
 l/s / nominal kW =

- Total l/s is greater than unit's minimum flow rate
- Total l/s meets job specified requirement of..... (l/s)

Perform TEST function (indicate positive result):

WARNING: *Once power is supplied to the unit, check the display for any alarms, such as phase reversal. Follow the TEST function instructions in the Controls and Troubleshooting literature (follow the procedure in the Controls IOM). Be sure that all service valves are open, before beginning the compressor test section.*

To start the chiller

WARNING: *Be sure that all service valves are open, and all pumps are on before attempting to start this machine. Once all checks have been made, move the switch to “LOCAL” or “REMOTE” from “OFF”*

Unit starts and operates properly

Temperatures and pressures

WARNING: *Once the machine has been operating for a while and the temperatures and pressures have stabilized, record the following:*

Evaporator EWT	Ambient temperature
Evaporator LWT	Condenser EWT
	Condenser LWT
Circuit A suction pressure	Circuit B suction pressure
Circuit A discharge pressure.....	Circuit B discharge pressure
Circuit A suction temperature.....	Circuit B suction temperature
Circuit A discharge temperature.....	Circuit B discharge temperature
Circuit A liquid line temperature.....	Circuit B liquid line temperature
.....	
Compressor oil pressure A1*	Compressor oil pressure B1*
Compressor oil pressure A2*	Compressor oil pressure B2*

* if installed

NOTE FOR 30RWA UNITS:

The pouch supplied with the unit contains the label indicating the refrigerant used and describing the procedure required under the Kyoto Protocol F-Gas Regulation:

- *Attach this label to the machine.*
- *Follow and observe the procedure described.*

NOTES:

.....
.....



Order No: 13431, 12.2016 - Supersedes order No: 13431, 11.2011.
The manufacturer reserves the right to make any changes, without notice.



www.eurovent-certification.com



Quality and Environment
Management Systems
Approval

Manufacturer: Carrier SCS, Montluel, France.
Printed in the European Union.