



United Technologies

PRODUCT SELECTION DATA

WATER CHILLERS HEAT PUMP



- Energy excellence
- Compact and reliable
- Twin-turbine centrifugal compressors
- Oil-Free compressors
- Flooded shell and tubes evaporator
- Self-adjusting electronic control
- Touch screen control interface

19PV

Cooling capacity 550-1600 kW
Heating capacity 650-1875 kW

The latest generation of **19PV** water chillers and water-to-water heat pumps are the perfect solution for all heating and cooling applications in the Office, Healthcare, Industry, Administration, Shopping centers, data centers and Collective Housing markets.

19PV is optimised to use ozone-friendly HFC R134a refrigerant.

This range guarantees compliance with the most demanding requirements for high energy efficiency and CO₂ reduction to comply with the various applicable European directives and regulations.

When producing chilled water, these units can be connected to a drycooler or a water cooling tower.

With the heat pump option, the units can produce hot water for heating applications. They can also be used in cooling mode by reversing the cycle on the hydronic circuits using a set of valves (hydraulic valves not supplied).



CARRIER participates in the ECP programme for LCP/HP
Check ongoing validity of certificate:
www.eurovent-certification.com

DESCRIPTION

■ 19PV, series

Very High Efficiency cooling or heating version

The product is optimised to meet the most demanding technical and economic requirements.

The product is optimised for very high energy efficiency applications for which optimum seasonal performance SEER values are required, ensuring operating costs are kept to a minimum.

19PV units are packaged machines supplied as standard with the following components:

- Maglev centrifugal semi-hermetic compressors
- No oil
- Shell and tube type chilled-water evaporator
- Shell and tube type hot water condenser
- Electrical power and remote control cabinet:
 - 400 V-3ph-50 Hz general power supply (+/-10%) + Earth
 - transformer fitted as standard on the machine for supplying the remote control circuit with 24 V
- Touch'Pilot electronic control module
- Casing for indoor installation

The entire 19PV range complies with the following EC directives and standards:

- Machinery Directive 2006/42/EC
- Electromagnetic Compatibility Directive 2014/30/EU
- EMC immunity and emissions EN 61800-3 'C2'
- Low Voltage Directive 2014/35/EU
- RoHS 2011/65/EU
- Pressure Equipment Directive (PED) 2014/68/EU
- Machinery Directive EN 60-204 -1
- Refrigeration systems and heat pumps EN 378-2.
- Regulation (EU) 2016/2281 implementing Directive 2009/125/EC with regard to ecodesign requirements

DESIGNATION

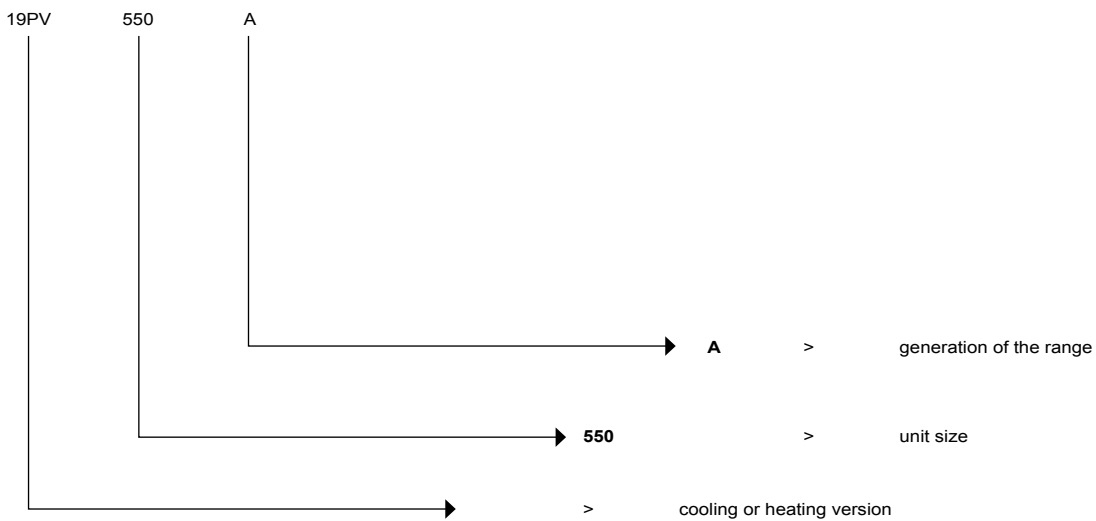

DESCRIPTION OF THE COMPONENTS

Twin-turbine centrifugal compressors,

- 2 Stages centrifugal compressors
- Optimized for R134a refrigerant
- Oil-free type
- Noiseless, vibration less via Magnetic levitation
- Compression ratio: from 1.5 to 5.0
- High efficiency permanent-magnet synchronous inverter motor.
- Linear step less capacity control via integrated inverter motor (up to 36000 rpm)
- Compressor equipped with Inlet Guide Valve at the turbine suction
- Compressor capacity control by successive use of speed variation swept volume variation at the turbine
- Integrated Soft- Start system (starting current limited to 5A)
- High Power Factor motor ($\cos\phi > 0.9$ for main operating conditions)
- Motor and electronic power section cooled by refrigerant
- Full electronic protection of motor against thermal and electrical overload via Internal sensors
- Rotation direction, no phase, under voltage, over voltage and power failure control
- Sensor on refrigerant suction and discharge for temperature monitoring
- Degree of protection: IP54

Shell and tube evaporator

- High performance glandless technology
- Copper tube bundle with internal and external grooves
- 19 mm thermal insulation
- Victaulic type coupling
- Maximum pressure, water side, of 10 bar.

Shell and tube condenser

- Copper tube bundle with internal and external grooves
- 19 mm thermal insulation (option)
- Built-in oil separator
- Victaulic type coupling
- Maximum pressure, water side, of 10 bar.

Refrigerant accessories

- Dehumidifier filters with rechargeable cartridges
- Hygroscopic sight glasses
- Electronic expansion valves
- Check-valve to prevent fluid recirculation in the compressor during transition phase

Regulation and safety instruments

- High and low pressure sensors
- Safety relief valves on refrigerating circuit
- High pressure switch on each compressor
- Evaporator antifreeze protection sensor
- Chilled water and hot water control sensors
- Electronic evaporator water circulation controller

Electrical cabinet

- Electrical cabinet index of protection IP23
- Safety disconnect switch
- 24 V control circuit
- Remote control transformer circuit
- Protection of the power and control circuits
- Touch'Pilot microprocessor-controlled electronic control module
- Electrical cabinet wire numbers
- Location of main components
- EMC filters and line reactors
- Door contact protection

Touch'Pilot control module

- User interface with 7 inch touchscreen
- Intuitive, user-friendly navigation using icons
- Clear information display in 10 languages (English, Spanish, French, German, Dutch, Turkish, Italian, Portuguese, Russian +1 Free)

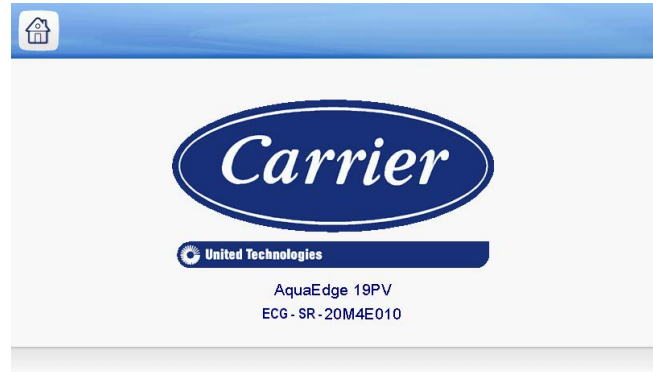

The electronic control module performs the following main functions:

- regulation of the chilled water temperature (at the return or at the outlet)
- regulation of the water temperature based on the outdoor temperature (water law)
- regulation for low temperature energy storage
- second setpoint management
- complete management of compressors with start-up sequence, timer and operating time balancing
- self-regulating and proactive functions with adjustment of settings on drift control
- continuous power control slide system on the compressors according to the thermal requirements
- management of compressor short cycle protection
- phase reversal protection
- management of occupied/unoccupied modes (according to the time schedule)
- equalisation of compressor operating hours
- condensing temperature limitation (Option 152)
- diagnosis of fault and operating statuses
- management of a fault memory allowing a log of the last 50 incidents to be accessed, with operating readings taken when the fault occurs
- blackbox memory
- master/slave management of two machines with equalisation of operating hours and automatic switching in case of a machine fault
- weekly and hourly time schedule for the machine, including 16 periods of absence
- display of all machine parameters (3 access levels, User/Maintenance/Factory, password-protected): temperature, setpoints, pressures, flow rate, operation time.
- display of trend curves for the main values
- storage of maintenance manual, wiring diagram and spare parts list.

Unit construction

- Electrical cabinet in light grey (RAL 7035)

DESCRIPTION OF THE COMPONENTS

Remote management

Touch'Pilot is equipped as standard with an ETHERNET (IP) connection, offering a range of options for remote management, monitoring and diagnostics.

Using the integrated Webserver, a simple internet connection uses the unit's IP address to access the Touch'Pilot interface on the PC, facilitating everyday management tasks and maintenance operations.

Numerous communication protocols are available: MODBUS/ JBUS TC/IP as standard, BACNET IP optional, enabling integration with most CMS/BMS

Several contacts are available as standard, enabling the machine to be controlled remotely by wired link:

- automatic operation control: when this contact is open, the machine stops
- setpoint 1/setpoint 2 selector: when this contact is closed, a second cooling setpoint is activated (energy storage or unoccupied mode, for example)
- heating/cooling operating mode selection
- fault reporting: this contact indicates the presence of a major fault which has caused one or both refrigerating circuits to stop
- operational status reporting indicates that the unit is in production mode
- Condenser flow switch
- setpoint adjustable via 4-20 mA signal: this input is used to adjust the active setpoint.
- power limitation adjustable by 4-20 mA signal
- power indication: analogue output (0-10 V) providing an indication of the unit's load rate.
- user fault reporting enables integration of a fault in the water loop
- general fault reporting: this contact indicates that the unit has stopped completely
- User interlock (open=unit shuts down / closed = enable to operate)
- alert reporting: this contact indicates the presence of a minor fault which has not caused the circuit affected to stop.
- end of storage signal: enables return to the second setpoint at the end of the storage cycle
- schedule override: closing this contact cancels the time schedule.
- Evaporator pump control (control by 0-10V command)

Direct access to technical literature

- Instruction manual
- Electrical diagram
- Spare parts list



Web server integrate as standard

IP address



Remote management via web server
 Connection to RJ port
 Connection via IP address
 All the HMI functionalities available on the PC
 Simplified remote monitoring



E-mail alerts (2 addresses)

Maintenance alert as standard

Touch'Pilot has two maintenance reminder functions as standard, making users aware of the need to regularly perform maintenance operations and to guarantee the service life and performance of the unit. These two functions can be activated independently.

A reminder message appears on the unit's HMI screen, and stays there until it is acknowledged by the maintenance operator. The information and alert relating to these functions are available on the communication bus to be used on the CMS/BMS.

- the scheduled maintenance reminder: when activated, this function enables the period between two maintenance inspections to be set. This period may be set by the operator in either days, months or operating hours, depending on the application.
- the compulsory F-GAS sealing test maintenance reminder: when activated, this function, which is the default factory setting, enables the period between two sealing tests to be selected, according to the refrigerant charge, in compliance with the F-GAS regulations.

OPTIONS

| Option | No. | Description | Advantage | Use 19PV |
|--|------|--|--|-----------|
| Low noise level | 15 | Discharge piping acoustic insulation | Up to 3 dB(A) quieter than standard unit | 0550-1600 |
| Master/slave operation | 58A | Unit equipped with supplementary water outlet temperature sensor kit (to be field installed) allowing master/slave operation of two units connected in parallel over Ethernet network (IP) | Optimised operation of two units connected in parallel operation with operating time equalisation | 0550-1600 |
| Single power connection point | 81 | Unit power connection via one main supply connection | Quick and easy installation | 0900-1600 |
| Evap. single pump power/control circuit | 84 | Unit equipped with an electrical power and control circuit for one pump evaporator side | Quick and easy installation: the control of fixed speed pumps is embedded in the unit control | 0550-1180 |
| Cond. single pump power/control circuit | 84R | Unit equipped with an electrical power and control circuit for one pump condenser side | Quick and easy installation: the control of fixed speed pumps is embedded in the unit control | 0550-1180 |
| Condenser insulation | 86 | Thermal condenser insulation | Minimizes thermal dispersions condenser side (key option for heat pump or heat recovery applications) | 0550-1600 |
| Service valve set | 92 | Liquid line valve (evaporator inlet) and compressor suction line valve | Allow isolation of various refrigerant circuit components for simplified service and maintenance | 0550-1600 |
| Evaporator with one pass less | 100C | Evaporator with one pass on the water side. Evaporator inlet and outlet on opposite sides. | Easy to install, depending on site. Reduced pressure drops | 0550-1600 |
| Condenser with one pass less | 102C | Condenser with one pass on the water side. Condenser inlet and outlet on opposite sides. | Easy to install, depending on site. Reduced pressure drops | 0550-1600 |
| Reversed evaporator water connections | 107 | Evaporator with reversed water inlet/outlet | Easy installation on sites with specific requirements | 0550-1600 |
| Reversed condenser water connections | 107A | Condenser with reversed water inlet/outlet | Easy installation on sites with specific requirements | 0550-1600 |
| Bacnet over IP | 149 | Bi-directional high-speed communication using BACnet protocol over Ethernet network (IP) | Easy and high-speed connection by ethernet line to a building management system. Allows access to multiple unit parameters | 0550-1600 |
| Control for low cond. temperature | 152 | Output signal (0-10 V) to control the condenser water inlet valve | Simple installation: for applications with cold water at condenser inlet (ex. ground-source, groundwater-source, superficial water-source applications) the signal permits to control a 2 or 3-way valve to maintain condenser water temperature (and so condensation) | 0550-1600 |
| Dry-cooler control | 154 | Remote control of 09PE or 09VE dry-cooler based on a 0-10V signal. The 09PE or 09VE dry-cooler shall be selected with control cabinet option | Easy system management, extended control capabilities of a remote dry-cooler | 0550-1600 |
| Input contact for Refrigerant leak detection | 159 | 0-10 V signal to report any refrigerant leakage in the unit directly on the controller (the leak detector itself must be supplied by the customer) | Immediate customer notification of refrigerant losses to the atmosphere, allowing timely corrective actions | 0550-1600 |
| Compliance with Swiss regulations | 197 | Additional tests on the water heat exchangers: supply (additional of PED documents) supplementary certificates and test certifications | Conformance with Swiss regulations | 0550-1600 |
| Compliance with Russian regulations | 199 | EAC certification | Conformance with Russian regulations | 0550-1600 |
| Welded evaporator connection kit | 266 | Victaulic piping connections with welded joints | Easy installation | 0550-1600 |
| Welded condenser water connection kit | 267 | Victaulic piping connections with welded joints | Easy installation | 0550-1600 |
| Flanged evaporator water connection kit | 268 | Victaulic piping connections with flanged joints | Easy installation | 0550-1600 |
| Flanged condenser water connection kit | 269 | Victaulic piping connections with flanged joints | Easy installation | 0550-1600 |
| 230V electrical plug | 284 | 230V AC power supply source provided with plug socket and transformer (180 VA, 0,8 Amps) | Permits connection of a laptop or an electrical device during unit commissioning or servicing | 0550-1600 |
| Free-cooling dry-cooler control | 313 | Remote control of 09PE or 09VE dry-cooler based on a 0-10V signal. The 09PE or 09VE dry-cooler shall be selected with control cabinet option | Easy system management, extended control capabilities of a remote dry-cooler used in free-cooling mode | 0550-1600 |
| Heat Pump application | 322 | Unit configured for Heat Pump application, includes thermal condenser insulation | Optimisation on heating mode & minimize thermal dispersions condenser side | 0550-1600 |

STANDARD UNIT TECHNICAL CHARACTERISTICS

| 19PV | | | 550 | 720 | 800 | 900 | 1010 | 1180 | 1300 | 1450 | 1600 | |
|--|--|--|----------------|--------------|--------------|--------------|--------------|--------------|--------------|--------------|--------------|--------------|
| Heating | | | | | | | | | | | | |
| Standard unit | HW1 | Nominal capacity | kW | 649 | 844 | 939 | 1050 | 1198 | 1389 | 1538 | 1700 | 1875 |
| | | COP | kW/kW | 6,13 | 6,26 | 5,93 | 5,79 | 5,89 | 5,76 | 5,97 | 5,89 | 5,67 |
| Full load performances* | HW2 | Nominal capacity | kW | 629 | 817 | 915 | 1039 | 1186 | 1351 | 1491 | 1648 | 1820 |
| | | COP | kW/kW | 4,89 | 4,81 | 4,63 | 4,68 | 4,68 | 4,53 | 4,72 | 4,62 | 4,50 |
| Seasonal energy efficiency** | HW1 | SCOP _{30/35°C} | kW/kW | 7,43 | 7,42 | 7,35 | 7,30 | 7,23 | 6,82 | 6,90 | 6,47 | 6,54 |
| | | η _{s heat} _{30/35°C} | % | 289 | 289 | 286 | 284 | 281 | 265 | 268 | 251 | 254 |
| | | P _{rated} | kW | 762,9 | 992,6 | 1103,3 | 1235,2 | 1409,4 | 1633,7 | 1808,7 | 2001,5 | 2202,7 |
| Cooling | | | | | | | | | | | | |
| Standard unit Full load performances* | CW1 | Nominal capacity | kW | 550,3 | 717,3 | 790,8 | 879,8 | 1007,0 | 1167,2 | 1302,3 | 1441,7 | 1577,8 |
| | | EER net | kW/kW | 5,39 | 5,53 | 5,18 | 5,02 | 5,15 | 5,13 | 5,38 | 5,42 | 5,13 |
| | | Eurovent class | | A | A | A | B | A | A | A | A | A |
| | | EER gross*** | | 5,55 | 5,70 | 5,32 | 5,14 | 5,30 | 5,33 | 5,63 | 5,69 | 5,39 |
| | CW2 | Nominal capacity | kW | 631 | 823 | 917 | 1014 | 1134 | 1348 | 1441 | 1638 | 1794 |
| | | EER net | kW/kW | 8,00 | 8,43 | 7,79 | 7,61 | 7,86 | 7,80 | 8,04 | 8,11 | 7,49 |
| | | Eurovent class | | A | A | A | A | A | A | A | A | A |
| | | EER gross*** | | 8,41 | 8,88 | 8,19 | 7,94 | 8,25 | 8,37 | 8,68 | 8,78 | 8,17 |
| Seasonal energy efficiency | SEER_{12/7°C} Comfort low temp. | | kW/kW | 9,70 | 9,55 | 9,54 | 9,79 | 9,59 | 9,49 | 9,50 | 9,48 | 9,14 |
| | SEER_{23/18°C} Comfort medium temp. | | kW/kW | 10,91 | 11,65 | 12,00 | 11,42 | 11,21 | 11,01 | 11,03 | 11,05 | 10,65 |
| | SEPR_{12/7°C} Process high temp. | | kWh/kWh | 9,48 | 10,31 | 9,78 | 9,05 | 9,26 | 9,44 | 9,49 | 9,75 | 9,32 |
| | ESEER | | kW/kW | 8,55 | 8,47 | 8,40 | 8,70 | 8,21 | 8,15 | 8,00 | 8,04 | 7,93 |
| | ESEER gross*** | | kW/kW | 9,74 | 9,62 | 9,48 | 9,79 | 8,96 | 9,66 | 9,51 | 9,74 | 9,77 |
| Sound levels | | | | | | | | | | | | |
| standard unit | | | | | | | | | | | | |
| Sound power ⁽¹⁾ | | | dB(A) | 89 | 92 | 94 | 92 | 94 | 95 | 94 | 95 | 97 |
| Sound pressure at 10 m ⁽²⁾ | | | dB(A) | 57 | 60 | 62 | 60 | 62 | 63 | 62 | 63 | 65 |
| Dimensions | | | | | | | | | | | | |
| Standard unit | | | | | | | | | | | | |
| Length | | | mm | 3140 | 3160 | 3360 | 4345 | 4345 | 4345 | 4800 | 4800 | 4800 |
| Width | | | mm | 1270 | 1310 | 1335 | 1385 | 1385 | 1385 | 1385 | 1390 | 1410 |
| Height | | | mm | 1780 | 1880 | 1965 | 2036 | 2036 | 2036 | 2000 | 2050 | 2100 |
| Operating weight⁽³⁾ | | | | | | | | | | | | |
| Standard unit | | | kg | 2402 | 2930 | 3376 | 4831 | 4855 | 4904 | 5504 | 6164 | 6730 |
| Compressors | | | | | | | | | | | | |
| MagLev compressor TT300 / TT350 | | | | | | | | | | | | |
| Circuit A | | | | 2 | 2 | 2 | 1 | 1 | 1 | 2 | 2 | 2 |
| Circuit B | | | | - | - | - | 2 | 2 | 2 | 2 | 2 | 2 |

* In accordance with standard EN14511-3:2013.

** In accordance with standard EN14825:2013, average climate

*** Values not Eurovent certified. Calculation without the impact of the exchanger pressure drop.

HW1 Heating mode conditions: Evaporator entering/leaving water temperature 10°C/7°C, condenser entering/leaving water temperature 30°C/35°C, evaporator and condenser fouling factor 0 m². k/W

HW2 Heating mode conditions: Evaporator entering/leaving water temperature 10°C/7°C, condenser entering/leaving water temperature 40°C/45°C, evaporator and condenser fouling factor 0 m². k/W

CW1 Cooling mode conditions: Evaporator water entering/leaving temperature 12°C/7°C, condenser entering/leaving water temperature 30°C/35°C, evaporator and condenser fouling factor 0 m². K/W

CW2 Cooling mode conditions: Evaporator water entering/leaving temperature 23°C/18°C, condenser entering/leaving water temperature 30°C/35°C, evaporator and condenser fouling factor 0 m². K/W

SEER_{12/7°C} & SEPR_{12/7°C} Applicable Ecodesign regulation: (EU) No 2016/2281

SEER_{23/18°C} Applicable Ecodesign regulation: (EU) No 2016/2281

(1) in dB ref=10⁻¹² W, 'A' weighted. Declared dual-number noise emission values in accordance with ISO 4871 with an associated uncertainty of +/-3dB(A). Measured in accordance with ISO 9614-1 and certified by Eurovent.

(2) In dB ref 20μPa, 'A' weighted. Declared dual-number noise emission values in accordance with ISO 4871 with an associated uncertainty of +/-3dB(A). For information, calculated from the sound power Lw(A).

(3) Values are guidelines only. Refer to the unit name plate.



Eurovent certified values

STANDARD UNIT TECHNICAL CHARACTERISTICS

| 19PV | | 550 | 720 | 800 | 900 | 1010 | 1180 | 1300 | 1450 | 1600 |
|------------------------------------|--------------------|--|-------|-------|-------|-------|-------|-------|-------|-------|
| Refrigerant⁽³⁾ | | R-134a | | | | | | | | |
| Circuit A | kg | 95,0 | 120,0 | 140,0 | 100,0 | 100,0 | 100,0 | 125,0 | 135,0 | 150,0 |
| | teqCO ₂ | 135,9 | 171,6 | 200,2 | 143,0 | 143,0 | 143,0 | 178,8 | 193,1 | 214,5 |
| Circuit B | kg | - | - | - | 125,0 | 125,0 | 125,0 | 125,0 | 135,0 | 150,0 |
| | teqCO ₂ | - | - | - | 178,8 | 178,8 | 178,8 | 178,8 | 193,1 | 214,5 |
| Capacity control | | Touch'Pilot, electronic expansion valves (EXV) | | | | | | | | |
| Minimum capacity | % | 15 | 10 | 10 | 10 | 10 | 10 | 10 | 10 | 10 |
| Evaporator | | Flooded multi-pipe type | | | | | | | | |
| Water volume | l | 115 | 165 | 180 | 285 | 285 | 285 | 330 | 330 | 365 |
| Water connections (Victaulic) | in | 6 | 6 | 8 | 8 | 8 | 8 | 8 | 8 | 8 |
| Drain and vent connections (NPT) | in | 3/8 | 3/8 | 3/8 | 3/8 | 3/8 | 3/8 | 3/8 | 3/8 | 3/8 |
| Max. water-side operating pressure | kPa | 1000 | 1000 | 1000 | 1000 | 1000 | 1000 | 1000 | 1000 | 1000 |
| Condenser | | Flooded multi-pipe type | | | | | | | | |
| Water volume | l | 145 | 157 | 187 | 308 | 308 | 308 | 339 | 487 | 487 |
| Water connections (Victaulic) | in | 6 | 6 | 8 | 8 | 8 | 8 | 8 | 8 | 8 |
| Drain and vent connections (NPT) | in | 3/8 | 3/8 | 3/8 | 3/8 | 3/8 | 3/8 | 3/8 | 3/8 | 3/8 |
| Max. water-side operating pressure | kPa | 1000 | 1000 | 1000 | 1000 | 1000 | 1000 | 1000 | 1000 | 1000 |

(3) Values are guidelines only. Refer to the unit name plate.

ELECTRICAL DATA NOTES FOR STANDARD UNITS

| 19PV | | 550 | 720 | 800 | 900 | 1010 | 1180 | 1300 | 1450 | 1600 |
|---|---------|----------|------|------|------|------|------|------|------|------|
| Power circuit supply | | | | | | | | | | |
| Nominal voltage | V-ph-Hz | 400-3-50 | | | | | | | | |
| Voltage range | V | 360-440 | | | | | | | | |
| Control circuit supply | | | | | | | | | | |
| 24 V via the built-in transformer | | | | | | | | | | |
| Maximum operating input power⁽¹⁾- Standard unit | | | | | | | | | | |
| Circuit 1 ^(a) | kW | 140 | 201 | 230 | 76 | 116 | 111 | 133 | 187 | 222 |
| Circuit 2 ^(a) | kW | - | - | - | 152 | 152 | 222 | 204 | 187 | 222 |
| Unit with option 81 | kW | - | - | - | 229 | 269 | 333 | 337 | 375 | 445 |
| Power factor at maximum power ⁽¹⁾ | | 0,92 | 0,92 | 0,92 | 0,92 | 0,92 | 0,92 | 0,92 | 0,92 | 0,92 |
| Total Harmonic Distortion Intensity | % | <45 | <45 | <45 | <45 | <45 | <45 | <45 | <45 | <45 |
| Nominal operating current draw⁽²⁾- Standard unit | | | | | | | | | | |
| Circuit 1 ^(a) | A | 162 | 208 | 244 | 93 | 129 | 119 | 151 | 210 | 243 |
| Circuit 2 ^(a) | A | - | - | - | 185 | 187 | 237 | 229 | 210 | 243 |
| Unit with option 81 | A | - | - | - | 278 | 315 | 356 | 380 | 420 | 486 |
| Maximum operating current draw (Un)⁽¹⁾- Standard unit | | | | | | | | | | |
| Circuit 1 ^(a) | A | 220 | 315 | 361 | 119 | 183 | 174 | 209 | 294 | 349 |
| Circuit 2 ^(a) | A | - | - | - | 239 | 239 | 349 | 319 | 294 | 349 |
| Unit with option 81 | A | - | - | - | 358 | 422 | 523 | 528 | 588 | 697 |
| Maximum current (Un-10%)⁽¹⁾- Standard unit | | | | | | | | | | |
| Circuit 1 ^(a) | A | 237 | 340 | 390 | 129 | 197 | 188 | 225 | 318 | 377 |
| Circuit 2 ^(a) | A | - | - | - | 258 | 258 | 377 | 345 | 318 | 377 |
| Unit with option 81 | A | - | - | - | 387 | 456 | 565 | 570 | 635 | 753 |
| Maximum start-up current(Un) - Standard unit⁽³⁾ | | | | | | | | | | |
| Lower than max current | | | | | | | | | | |
| Dissipated power of electrical equipment ⁽¹⁾ | W | 782 | 1249 | 1249 | 1144 | 1347 | 1814 | 1884 | 2351 | 2351 |

(1) Values obtained at unit continuous maximum operating conditions (data given on the unit nameplate)

(2) Standardised EUROVENT conditions, water-cooled exchanger water inlet/outlet = 12°C/7°C, condenser entering/leaving water temperature = 30°C/35°C

(3) Start-up current is limited by the soft-start controller included in the compressor.

(a) When the machines are equipped with two power supplies, circuit 1 supplies the refrigerant circuit A and circuit 2 supplies the refrigerant circuit B

Note: Options 84 and 84R are not included in these values.

| 19PV | | 550 | 720 | 800 | 900 | 1010 | 1180 | 1300 | 1450 | 1600 |
|--|----|-----|-----|-----|-----|------|------|------|------|------|
| Short-circuit withstand current (TN system) | | | | | | | | | | |
| Circuit A+B | KA | 50 | 50 | 50 | 50 | 50 | 50 | 50 | 50 | 50 |

(1) If another current limitation protection device is used, its time-current and thermal constraint (I²t) trip characteristics must be at least equivalent to those of the recommended protection.

Note: The short-circuit stability current values above are suitable with the TN system.

ELECTRICAL DATA NOTES FOR STANDARD UNITS

Electrical data notes and operating conditions, 19PV units

• As standard:

19PV 550 to 19PV800 units have a single power connection point located immediately upstream of the main supply disconnect switch.

19PV 900 to 19PV 1600 units have two connection points located immediately upstream of the main supply disconnect switches.

• Control box includes the following standard features:

- Two disconnect switches per circuit: One main supply disconnect switch and one disconnect switch for the supply of the control part, the undervoltage protection circuit and the motor mechanism module,
- Filtering compressor current devices
- Anti-short cycle protection devices
- Control devices supply by internal transformers.

• Field connections:

All connections to the system and the electrical installations must be in accordance with all applicable codes.*

- 19PV units are designed and built to ensure conformance with these codes. The recommendations of European standard EN 60204-1 (corresponds to IEC 60204-1) (machine safety - electrical machine components - part 1: general regulations) are specifically taken into account, when designing the electrical equipment.
- Generally the recommendations of IEC 60364 are accepted as compliance with the requirements of the installation regulation.
- Annex B of standard EN 60204-1 specifies the electrical features used for the operation of the units. The features below complete the informations given in this document:

1. Physical environment:

The classification of environment is specified in standard EN 60364:

- Indoor installation**,
- Ambient temperature range: minimum temperature +5°C to +42°C, class AA4
- Altitude: AC1 of 2000 m or less,
- Presence of water: Class AD2 (possibility of water droplets)**
- Presence of hard solid: Class AE2 (no significant dust present)**,
- Presence of corrosive and polluting substances, class AF1 (negligible),
- Competence of persons: BA4 (Persons wise),
- Overvoltage category: II (2,5KV).

2. Compatibility for low-frequency conducted disturbances according to class 2 levels per IEC61000-2-4 standard:

- Power supply frequency variation: +- 2Hz
- Phase imbalance : 2%

3. The neutral (N) line must not be connected directly to the unit (if necessary use a transformer).

4. Overcurrent protection of the power supply conductors is not provided with the unit.

5. The factory-installed disconnect switch(es)/circuit breaker(s) are of a type suitable for power interruption in accordance with EN 60947-3 (corresponds to IEC 60947-3).

6. The units are designed for connection to TN networks (IEC 60364). In IT networks, if noise filters are integrated into the compressor(s) variable frequency drive(s), this will render the units unsuitable for their intended purpose. In addition, the equipment characteristics in case of insulation failure are modified.

For IT networks, the earth connection must not be at the network earth. Provide a local earth; consult competent local organisations to complete the electrical installation.

7. Electromagnetic environment: classification of the electromagnetic environment is described in standard EN 61800-3 (corresponds to IEC 61800-3):

- Immunity to external interference defined by the second environment***
- Interference emission as defined in category C2

Warning: In a residential environment, this product may cause radio interference in which case additional mitigation measures could be required.

The compressor variable frequency drive is a source of perturbations from the harmonic currents. An investigation could be necessary to check that the perturbations don't exceed the compatibility limits with the other devices connected on the same power supply network. In an electrical installation, the levels of compatibility to be observed at the internal coupling point (IPC) to which other loads are connected are described in standard IEC 61000-2-4.

- Leakage currents: If protection by monitoring the leakage currents is necessary to ensure the safety of the installation, the presence of additional leakage currents introduced by the use of variable frequency drive(s) in the compressor must be considered.

In particular, the reinforced immunity protection types and a control value not lower than 150 mA are recommended when selecting differential protective devices.

Note: If particular aspects of an actual installation do not conform to the conditions described above, or if there are other conditions which should be considered, always contact your local Carrier representative.

* Generally, the recommendations of the standard of International Electrotechnical Commission (IEC60364) are identified to meet the requirements of the installation guidelines.

** The required protection level for this class is IP21B or IPX1B (according to reference document IEC 60529). All 19PV units are IP23 and fulfil this protection condition.

***Example of second environment installations: Industrial areas, technical facilities supplied by a dedicated transformer

PARTIAL LOAD PERFORMANCE

With the rapid increase in energy costs and the care about environmental impacts of electricity production, power consumption of air conditioning equipment has become an important topic.

The energy efficiency of a unit at full load is rarely representative of the actual performance of the units, as on average a unit works less than 5% of the time at full load.

SEER for comfort chillers (in accordance with EU ECODESIGN)

The **SEER (Seasonal Energy Efficiency Ratio)** measures the seasonal energy efficiency of comfort **chillers** by calculating the ratio between annual cooling demand of the building and annual energy demand of the chiller. It takes into account the energy efficiency achieved for each outdoor temperature weighted by the number of hours observed for each of these temperatures, using actual climate data.

SEER is a new way of measuring the true energy efficiency of chillers for comfort cooling over an entire year. This new indicator gives a more realistic indication of the real energy efficiency and environmental impact of a cooling system (Ecodesign Regulation 2016/2281).

The heat load of a building depends on many factors, such as the outdoor air temperature, the exposure to the sun and its occupancy.

Consequently, it is preferable to use the average seasonal energy efficiency, calculated at several operation points that are representative of unit use.

ESEER (in accordance with EUROVENT)

The **ESEER (European Seasonal Energy Efficiency Ratio)** permits evaluation of the average energy efficiency at part load, based on four operating conditions defined by Eurovent. The ESEER is the average value of energy efficiency ratios (EER) at different operating conditions, weighted by the operating time.

| Load % | Condenser entering water temperature, °C | Energy efficiency | Operating time, % |
|--------|--|-------------------|-------------------|
| 100 | 30 | EER ₁ | 3 |
| 75 | 26 | EER ₂ | 33 |
| 50 | 22 | EER ₃ | 41 |
| 25 | 18 | EER ₄ | 23 |

$$ESEER = EER_1 \times 3\% + EER_2 \times 33\% + EER_3 \times 41\% + EER_4 \times 23\%$$

Note: Constant leaving chilled water temperature 7°C.

SEPR for process chillers (in accordance with EU ECODESIGN)

The **SEPR (Seasonal Energy Performance Ratio)** measures the seasonal energy efficiency of **process chillers** by calculating the ratio between annual cooling demand of the process and annual energy demand of the chiller. It takes into account the energy efficiency achieved at each outdoor temperature of an average climate weighted by the number of hours observed for each of these temperatures.

SEPR is a new way of measuring the true energy efficiency of chillers for **process cooling** over an entire year. This new indicator gives a more realistic indication of the real energy efficiency and environmental impact of the cooling system (Ecodesign Regulation 2015/1095 or 2016/2281).

SOUND LEVELS

Standard Units

Sound power levels ref 10^{-12} W ± 3 dB (L_w)

| 19PV | SOUND POWER LEVEL SPECTRUM (dB) | | | | | | | Overall power level dB(A) |
|------|---------------------------------|--------|--------|---------|---------|---------|---------|---------------------------|
| | 125 Hz | 250 Hz | 500 Hz | 1000 Hz | 2000 Hz | 4000 Hz | 8000 Hz | |
| 550 | 71 | 77 | 78 | 85 | 80 | 79 | 84 | 89 |
| 720 | 72 | 77 | 84 | 84 | 80 | 86 | 89 | 92 |
| 800 | 76 | 81 | 85 | 86 | 83 | 87 | 92 | 94 |
| 900 | 76 | 82 | 82 | 88 | 84 | 82 | 88 | 92 |
| 1010 | 77 | 82 | 85 | 88 | 84 | 85 | 91 | 94 |
| 1180 | 77 | 82 | 86 | 87 | 84 | 88 | 93 | 95 |
| 1300 | 75 | 80 | 85 | 88 | 83 | 87 | 90 | 94 |
| 1450 | 75 | 80 | 87 | 87 | 83 | 89 | 92 | 95 |
| 1600 | 79 | 84 | 88 | 89 | 86 | 90 | 95 | 97 |

Sound pressure level ref 2×10^{-5} Pa ± 3 dB (L_p)

Measurement conditions: free field, 10 metres from machine, 1.50 metres above floor level, directivity 2

| 19PV | SOUND PRESSURE SPECTRUM (dB) | | | | | | | Overall power level dB(A) |
|------|------------------------------|--------|--------|---------|---------|---------|---------|---------------------------|
| | 125 Hz | 250 Hz | 500 Hz | 1000 Hz | 2000 Hz | 4000 Hz | 8000 Hz | |
| 550 | 39 | 45 | 46 | 54 | 48 | 48 | 52 | 57 |
| 720 | 40 | 45 | 52 | 52 | 48 | 54 | 57 | 60 |
| 800 | 44 | 49 | 53 | 54 | 51 | 55 | 60 | 62 |
| 900 | 44 | 49 | 50 | 55 | 52 | 50 | 56 | 60 |
| 1010 | 45 | 50 | 53 | 56 | 52 | 53 | 59 | 62 |
| 1180 | 44 | 50 | 54 | 55 | 52 | 55 | 61 | 63 |
| 1300 | 42 | 48 | 53 | 56 | 51 | 55 | 58 | 62 |
| 1450 | 42 | 48 | 55 | 55 | 50 | 56 | 60 | 63 |
| 1600 | 46 | 52 | 56 | 57 | 54 | 57 | 63 | 65 |

Note: The sound levels by octave bands are given for information only and not contractually binding. Only the overall power level is contractual.

Low noise option (Option 15)

Sound power levels ref 10^{-12} W ± 3 dB (L_w)

| 19PV | SOUND POWER LEVEL SPECTRUM (dB) | | | | | | | Overall power level dB(A) |
|------|---------------------------------|--------|--------|---------|---------|---------|---------|---------------------------|
| | 125 Hz | 250 Hz | 500 Hz | 1000 Hz | 2000 Hz | 4000 Hz | 8000 Hz | |
| 550 | 72 | 78 | 79 | 85 | 79 | 77 | 81 | 88 |
| 720 | 71 | 78 | 83 | 82 | 78 | 83 | 84 | 89 |
| 800 | 84 | 82 | 85 | 85 | 81 | 83 | 87 | 91 |
| 900 | 71 | 82 | 82 | 88 | 83 | 79 | 84 | 91 |
| 1010 | 81 | 83 | 84 | 88 | 83 | 82 | 86 | 92 |
| 1180 | 85 | 83 | 86 | 86 | 82 | 84 | 88 | 92 |
| 1300 | 75 | 81 | 85 | 87 | 82 | 84 | 86 | 92 |
| 1450 | 74 | 81 | 86 | 85 | 81 | 86 | 87 | 92 |
| 1600 | 87 | 85 | 88 | 88 | 84 | 86 | 90 | 94 |

OPERATING LIMITS AND OPERATING RANGES

| 19PV | | Minimum | Maximum |
|---|----|-------------------|---------|
| Evaporator | | | |
| Entering temperature at start-up | °C | - | 35 |
| Leaving temperature during operation | °C | 3,3 | 20 |
| Entering/leaving water temperature difference | K | 3 | 11,1 |
| Condenser | | | |
| Entering temperature at start-up | °C | 13 ⁽¹⁾ | - |
| Leaving temperature during operation | °C | 14 ⁽¹⁾ | 50 |
| Entering/leaving water temperature difference | K | 3 | 11,1 |

(1) For lower condenser temperatures a water flow control valve must be used at the condenser (two or three-way valve). Please refer to Control for low condensing temperature option to ensure the correct condensing temperature.

19PV MAP

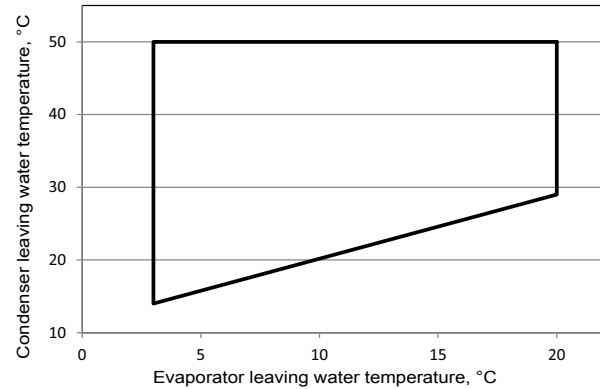

NOTES: Ambient temperatures: During storage and transport of the 19PV units (including by container) the minimum and maximum permissible temperatures are -20°C and 66°C.

For more precise details refer to the unit selection program.

SYSTEM WATER VOLUME - EXCHANGER WATER FLOW RATE

The Touch'Pilot controller is equipped with anticipation logic making it highly flexible in adjusting operation to parameter drift, particularly on hydraulic systems with low water volumes. By adjusting compressor running times, it prevents short-cycle protection cycles from starting and, in most cases, eliminates the need for a buffer tank.

Note: The minimum volumes of water are calculated on EUROVENT rated conditions:

- Chilled water temperature = 12°C/7°C
- Condenser water temperature = 30°C/35°C

This value is applicable for most air conditioning applications (unit with fan coil units).

Note: For installations running with a low volume of water (unit with air handling unit) or for industrial processes, the buffer tank is essential.

| 19PV | 550 | 720 | 800 | 900 | 1010 | 1180 | 1300 | 1450 | 1600 |
|---|------|------|------|------|------|------|------|------|-------|
| Minimum installation volume (l) | | | | | | | | | |
| Air conditioning application | 1770 | 2310 | 2570 | 2890 | 3240 | 3790 | 4170 | 4640 | 5130 |
| Industrial process application | 3530 | 4620 | 5140 | 5780 | 6480 | 7570 | 8330 | 9290 | 10250 |
| Evaporator water flow rate (m³/h) | | | | | | | | | |
| Minimum ⁽¹⁾ | 34 | 34 | 34 | 34 | 61 | 61 | 61 | 61 | 61 |
| Maximum ⁽³⁾ | 179 | 235 | 257 | 281 | 289 | 286 | 295 | 295 | 329 |
| Condenser water flow rate (m³/h) | | | | | | | | | |
| Minimum ⁽²⁾ | 21 | 21 | 36 | 36 | 36 | 36 | 36 | 36 | 36 |
| Maximum ⁽³⁾ | 245 | 299 | 346 | 486 | 457 | 454 | 428 | 594 | 526 |

(1) Minimum evaporator flow rate based on a water velocity of 0,5 m/s.

(2) Minimum condenser flow rate based on a water velocity of 0,3 m/s.

(3) Maximum flow rate based on a pressure drop of 120 kPa (units with two evaporator passes and two condenser passes).

EVAPORATOR PRESSURE DROP CURVES

Units with two evaporator passes (standard):

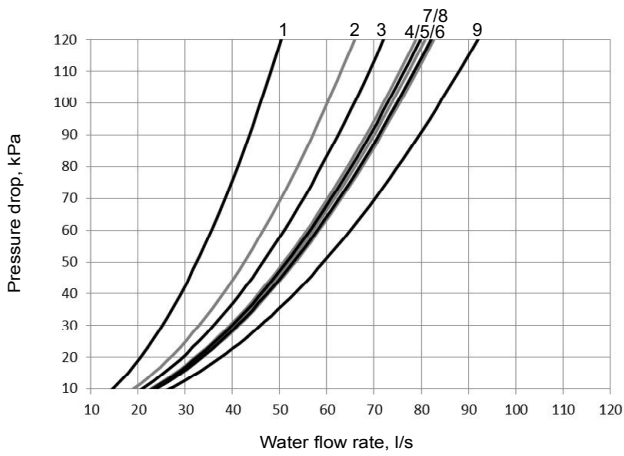

Legend

- | | |
|------------|------------|
| 1 19PV550 | 6 19PV1180 |
| 2 19PV720 | 7 19PV1300 |
| 3 19PV800 | 8 19PV1450 |
| 4 19PV900 | 9 19PV1600 |
| 5 19PV1010 | |

Units with evaporator with one pass less (evaporator with option 100C):

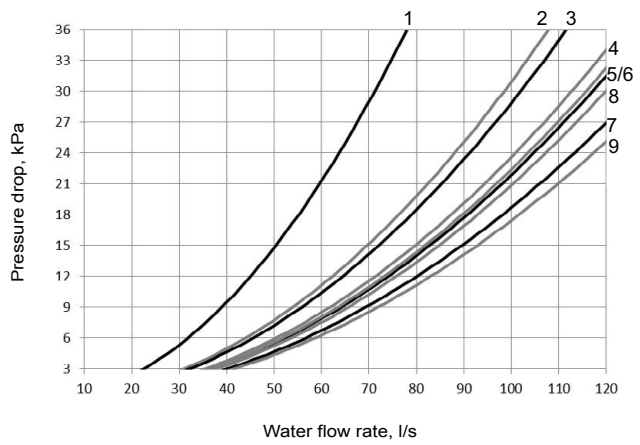

Legend

- | | |
|------------|------------|
| 1 19PV550 | 6 19PV1180 |
| 2 19PV720 | 7 19PV1300 |
| 3 19PV800 | 8 19PV1450 |
| 4 19PV900 | 9 19PV1600 |
| 5 19PV1010 | |

CONDENSER PRESSURE DROP CURVES

Units with two condenser passes (standard):

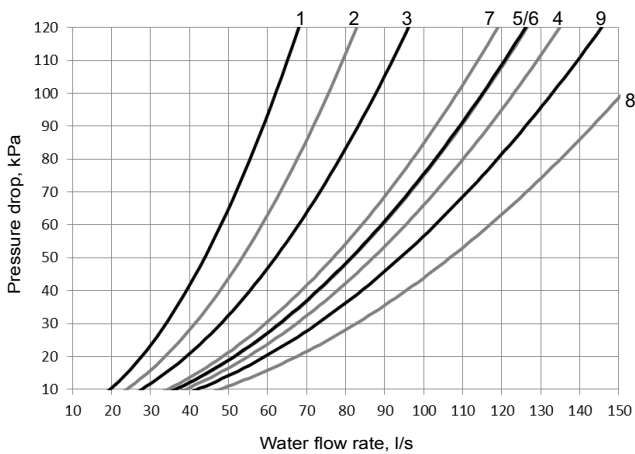

Legend

- | | |
|------------|------------|
| 1 19PV550 | 6 19PV1180 |
| 2 19PV720 | 7 19PV1300 |
| 3 19PV800 | 8 19PV1450 |
| 4 19PV900 | 9 19PV1600 |
| 5 19PV1010 | |

Units with condenser with one pass less (condenser with option 102C):

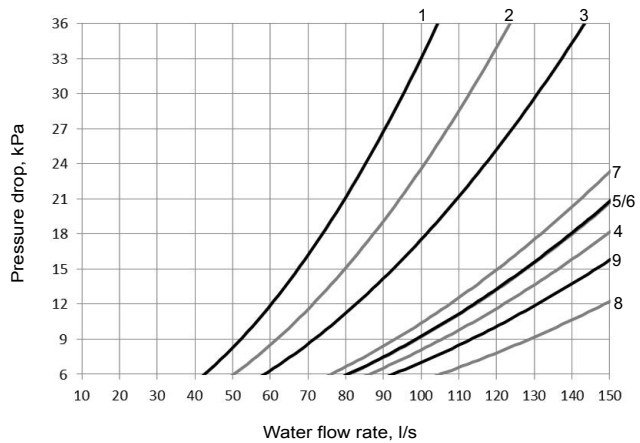

Legend

- | | |
|------------|------------|
| 1 19PV550 | 6 19PV1180 |
| 2 19PV720 | 7 19PV1300 |
| 3 19PV800 | 8 19PV1450 |
| 4 19PV900 | 9 19PV1600 |
| 5 19PV1010 | |

DIMENSIONS

19PV 550 to 800

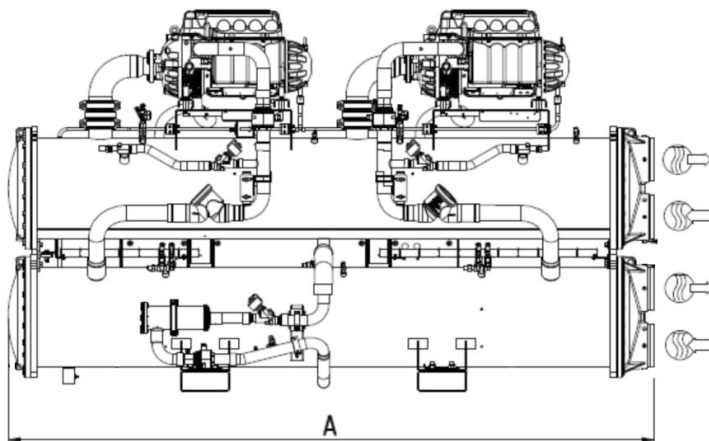
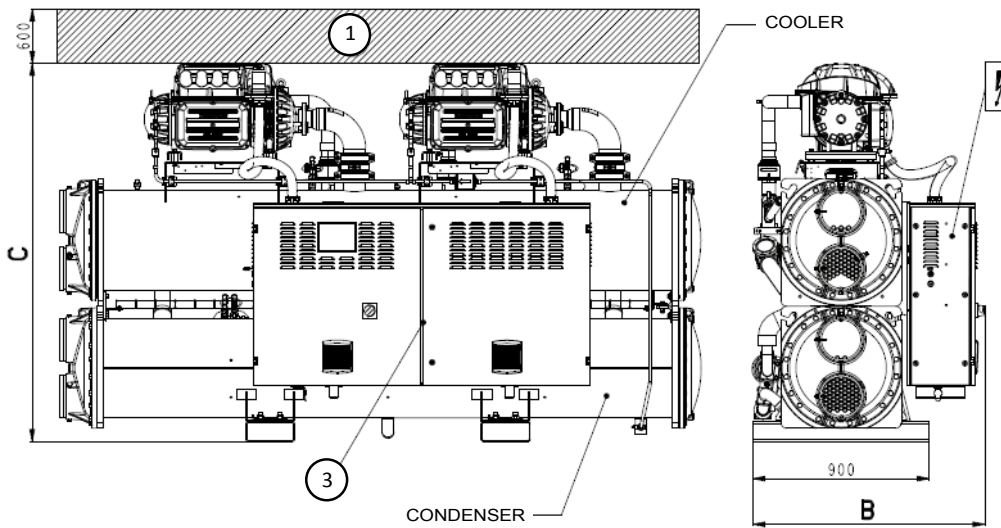

| Units sizes | Dimensions in mm | | | |
|-------------|------------------|------|------|------|
| | A | B | C | D |
| 19PV | | | | |
| 550 | 3045 | 1120 | 1745 | 2800 |
| 720 | 3070 | 1155 | 1846 | 2800 |
| 800 | 3270 | 1190 | 1925 | 3000 |

Legend:

All dimensions are given in mm.

- ① Required clearance for maintenance
- ② Recommended clearance for tube removal
- Water inlet
- Water outlet
- Electrical cabinet

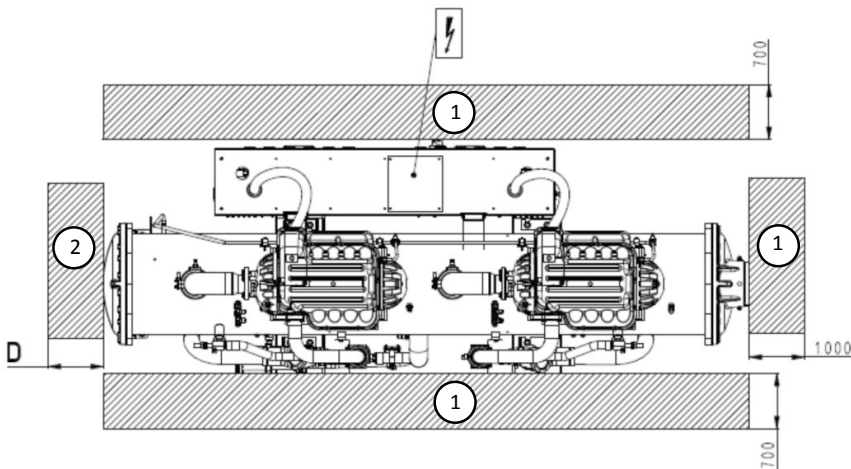

NOTE: Drawings are not contractually binding. Before designing an installation, consult the certified dimensional drawings, available on request.

DIMENSIONS

19PV 900 to 1180

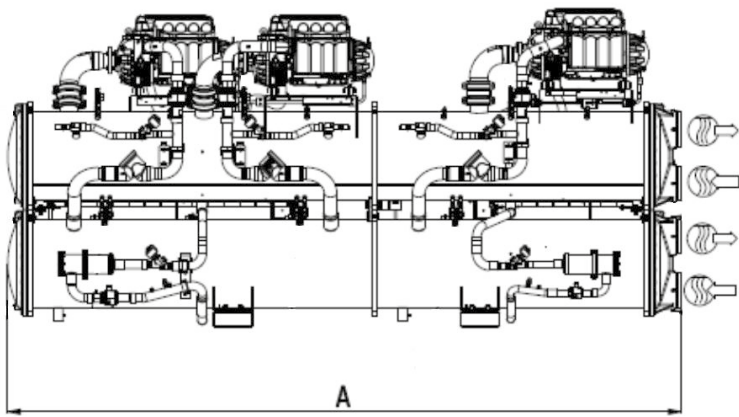
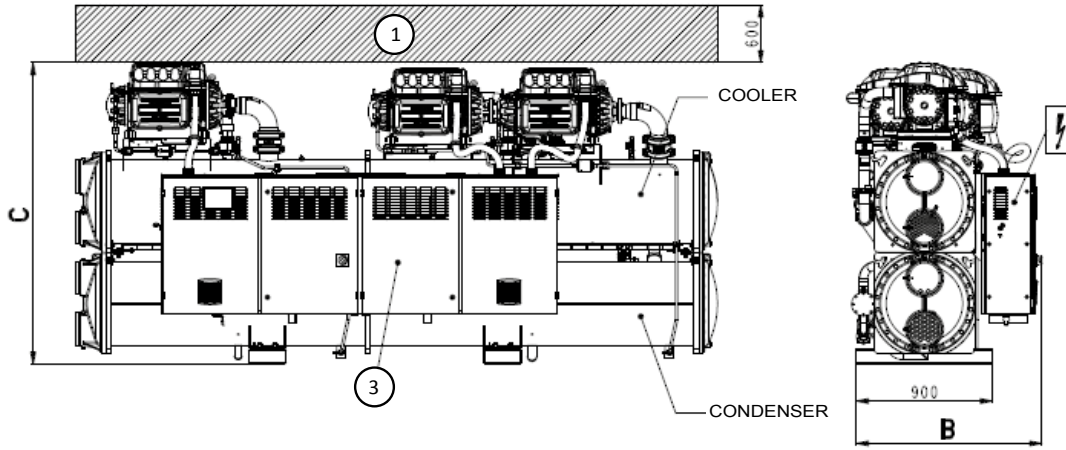

| Units sizes | Dimensions in mm | | | |
|-------------|------------------|------|------|------|
| | A | B | C | D |
| 19PV | | | | |
| 900 | 4257 | 1290 | 1955 | 3950 |
| 1010 | 4257 | 1290 | 1955 | 3950 |
| 1180 | 4257 | 1290 | 1955 | 3950 |

Legend:

All dimensions are given in mm.

- ① Required clearance for maintenance
- ② Recommended clearance for tube removal
- Water inlet
- Water outlet
- Electrical cabinet

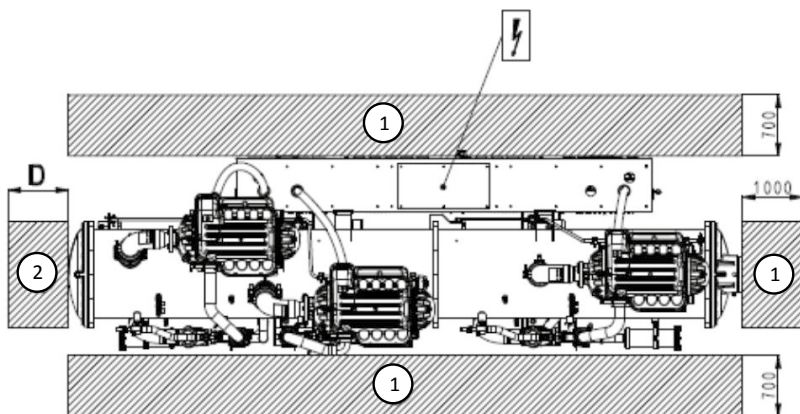

NOTE: Drawings are not contractually binding. Before designing an installation, consult the certified dimensional drawings, available on request.

DIMENSIONS

19PV 1300 to 1600

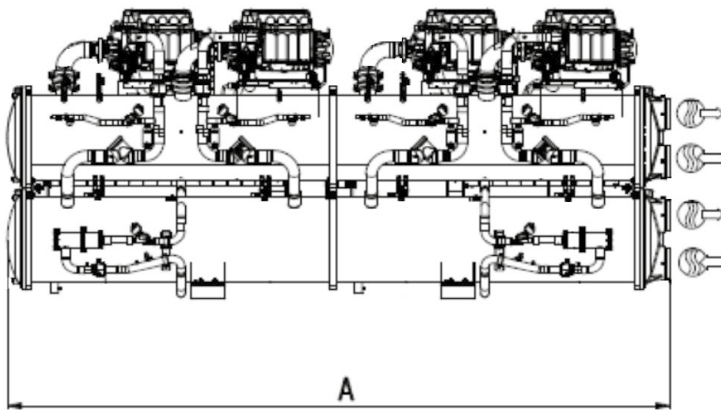
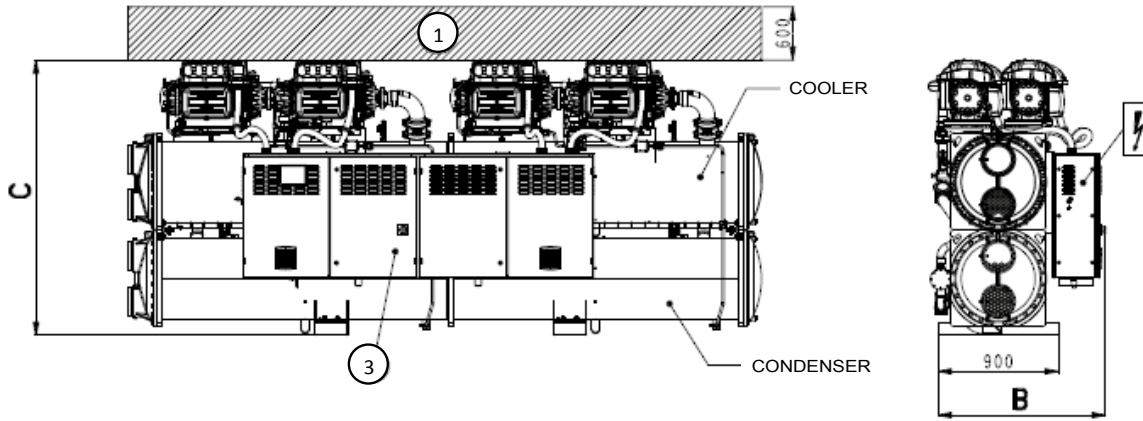

| Units sizes | Dimensions in mm | | | |
|-------------|------------------|------|------|------|
| | A | B | C | D |
| 19PV | | | | |
| 1300 | 4705 | 1290 | 1955 | 4400 |
| 1450 | 4740 | 1290 | 2011 | 4400 |
| 1600 | 4740 | 1325 | 2065 | 4400 |

Legend:

All dimensions are given in mm.

- ① Required clearance for maintenance
- ② Recommended clearance for tube removal
- Water inlet
- Water outlet
- Electrical cabinet

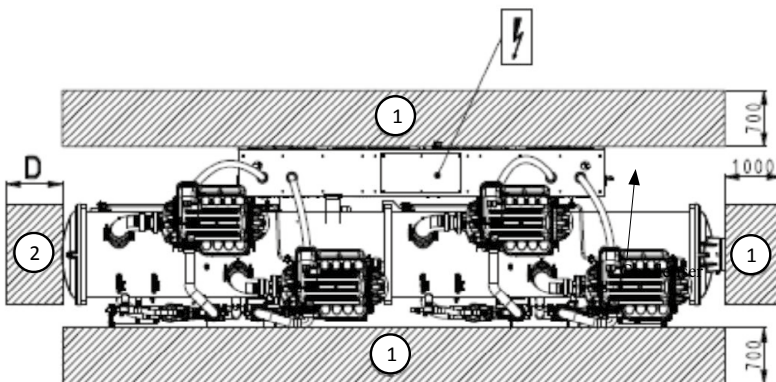

NOTE: Drawings are not contractually binding. Before designing an installation, consult the certified dimensional drawings, available on request.

SPECIFICATION GUIDE

General

Chilled and hot water will be produced by a **CARRIER 19PV-type** water-to-water unit, which is a single unit assembly designed for indoor installation

The chiller (or heat pump) will use environmentally-friendly **R134a** refrigerant. It will include 1 or 2 independent cooling circuits and will be equipped with 2, 3 or 4 MagLev centrifugal compressors, depending on the model.

The unit will be designed, produced and tested at a production plant with a quality-assurance system which is certified according to **ISO 9001, 14001 and 50001**. Performance levels will be certified by the **EUROVENT association within the limits of the certification programme**

The machine will be covered by an EC declaration of conformity and will comply with the following European regulations and standards:

- Machinery Directive 2006/42/EC and EN 60-204 -1
- Electromagnetic Compatibility Directive 2014/30/EU
- EMC Immunity and Emissions EN 61800-3 "C2"
- Low Voltage Directive 2014/35/EU
- RoHS 2011/65/EU
- Pressure Equipment Directive (PED) 2014/68/EU
- Refrigeration systems and heat pumps EN 378-2.
- Regulation (EU) 2016/2281 implementing Directive 2009/125 EC with regard to ecodesign requirements.

Performance levels (Insert the simplified description from the ECAT software)

Cooling capacity (kW):

Total electrical power used: kW

Heating capacity: kW

Minimum EER net coefficient of performance at full load according to the EN14511:3-2013 standard:....

Minimum COP net coefficient of performance at full load according to the EN14511:3-2013 standard:....

Minimum SEER seasonal coefficient of performance according to the Ecodesign Regulation 2016/2281 (ENER LOT 21) standard certified by the independent association Eurovent (mandatory):....

Minimum SCOP seasonal coefficient of performance in heating according to the EN 813/2013 standard

Evaporator chilled water entering/leaving temperature: .../...°C

Pressure drops for the evaporator:

Secondary fluid:

Condenser hot water entering/leaving temperature: .../...°C

Pressure drop for the condenser:

Secondary fluid:

Type of refrigerant: R134a (ODP=0 / GWP=1430)

CO₂ equivalent tonne:

Dimensions (length x width x height):x.....x..... mm

Unit operating weight: Kg

The environmental report including the analysis of the life cycle of the unit must be supplied by the manufacturer

The unit shall be capable of starting up with a condenser entering water temperature of **13°C with the control option for low condensing temperature**. The unit must be capable of starting up with an evaporator entering water temperature of **35°C**.

Compressors

These components are 2 Stages centrifugal compressors with a variable speed motor cooled by suction refrigerant gas, and protected against overheating.

They will include the following standard components:

- 2 Stages centrifugal compressors
- Oil-free type ensuring:
 - elimination of lubricating system,
 - pipe simplification
 - improvement of the performance of the exchangers due to absence of oil film between the refrigerant and the heat exchange surfaces
- Magnetic levitation bearings ensuring :
 - absence of friction and increase of compressor lifetime
 - absence of vibration and noise reduction
- High efficiency permanent-magnet synchronous inverter motor.
- Linear step less capacity control via integrated inverter motor (up to 36000 rpm)
- Compressor capacity control by successive use of speed variation swept volume variation at the turbine ensuring:
 - exact capacity match
 - very high efficiency values at partial loads
- Compressor equipped with Inlet Guide Valve at the turbine suction
- Integrated Soft- Start system (starting current limited to 5A) This allows a favorable selection of the electrical protection devices.
- High Power Factor motor ($\cos\phi > 0.9$ for main operating conditions)
- Motor and electronic power section cooled by refrigerant
- Full electronic protection of motor against thermal and electrical overload via Internal sensors
- Rotation direction, no phase, under voltage, over voltage and power failure control
- Sensor on refrigerant suction and discharge for temperature monitoring
- Internal over pressure safety and check valves to prevent reverse rotation while transition period
- Degree of protection: IP54

■ **Service valves (Option 92)**

Shut-off valves on the liquid line (evaporator inlet) and on the compressor suction line to facilitate maintenance

Evaporator

A single, high-performance, glandless-type evaporator with copper tube bundle with internal and external grooves

The design includes 1 or 2 independent cooling circuits.

Two entering and leaving water temperature sensors on the exchanger are used to regulate the 'return water' or 'leaving water'.

The heat insulation is made from shaped cellular foam, **at least 19 mm thick**.

The hydraulic unions will be "**VICTAULIC**"-type unions to ensure quick connection between the unit and hydraulic system (Option 268).

The maximum operating pressure on the water side is **10 bar**

The evaporator will be equipped with an electronic flow controller. Paddle-type sensors or differential pressure controllers shall not be acceptable.

Several choices of hydraulic connections will be available on the evaporator to adapt to all possible constraints (see options available)

SPECIFICATION GUIDE

Condenser

A single condenser with copper tube bundle with internal and external grooves

The design includes 1 or 2 independent cooling circuits

Two entering and leaving water temperature sensors on the exchanger are used to regulate the 'return water' or 'leaving water'.

The heat insulation is made from shaped cellular foam, **at least 19 mm thick (Option 86 or option 322)**

The hydraulic unions will be "VICTAULIC"-type unions to ensure quick connection between the unit and hydraulic system (Flanged connections in option 269).

The maximum operating pressure on the water side is **10 bar**
Several choices of hydraulic connections will be available on the evaporator to adapt to all possible constraints (see options available)

- **Condenser thermal insulation (Option standard in option 322)**
To minimise heat losses, the condenser will be equipped with insulation made from 19-mm-thick shaped cellular foam. This option will be included as standard for heat pump applications

Refrigerating components - Safety devices

Each cooling circuit will include the following accessories as a minimum:

- Two electronic expansion valves
- One liquid sight glass to show the refrigerant condition
- Check-valve to prevent fluid recirculation in the compressor during transition phase
- High and low pressure sensors
- Pressure safety valves on refrigerant circuit
- High pressure switch on each compressor
- Evaporator antifreeze protection sensor
- **Factory-fitted electronic water flow controller**

Electrical cabinet

The electrical cabinet is made from painted steel sheet metal with an **IP23 protection** rating and include EMC filters and line reactors

The power supply is 400 V (+10/-10%) 3-ph 50 Hz + earth without neutral.

The electrical cabinet includes a main external safety switch and a 24-V control circuit supply transformer

The access to the electrical cabinet is protected by Doors contact.

The internal wiring of the electrical panel is numbered and all the electrical components are marked.

- **Pump power/control circuit (option 84/84R)**
The unit is equipped with a control/power supply circuit to control one external single pump on the evaporator side and/or on the condenser side

Touch'Pilot electronic control, regulation and display module

The control module features a 7-inch touchscreen with a user-friendly operator interface enabling intuitive navigation using icons.

User interface

- 7-inch colour screen
- Display of all machine parameters (3 access levels, User/Maintenance/Factory, password-protected)
- **Display of trend curves for main values**
- **9 languages available. One additional local languages can be insert**
- Possibility to load a custom translation file
- Access to the interface through the web browser

Control

This performs the following functions:

- Regulation of the water temperature (at the return or at the outlet)
- Option of varying the setpoint according to the outdoor temperature
- Second setpoint management
- Management of compressors with start-up sequence, metering and operating time balancing
- Self-regulating and proactive functions with adjustment of drift control for parameters
- Management of compressor short cycle protection
- Protection against phase inversion
- Weekly and hourly time schedule for the machine, including 16 periods of absence
- Condensing pressure limitation (option 152)
- Diagnosis of fault and operating statuses
- Management of a fault memory allowing a log of the last 50 incidents to be accessed, with operating readings taken when the fault occurs
- **blackbox memory**
- Master/slave management of the two machines in parallel with operating time balancing and automatic changeover if a fault occurs on one machine
- **The maintenance manual, wiring diagram** and list of spare parts for the machine are available in electronic format

Maintenance function

The controller will have two maintenance reminder functions as standard, making the user aware of the need to regularly perform maintenance operations and to guarantee the service life and performance of the machine

- **Periodic reminder:** this function is used to select the period between two maintenance checks. This period may be set by the operator in either days, months or operating hours, depending on the application
- **Mandatory F-GAS sealing test reminder:** this function is activated by default in the factory and is used to select the period between two sealing tests depending on the refrigerant charge of the machine in accordance with F-GAS regulations

Remote control

- Communication with CMS via MODBUS/JBS TC/IP output as standard.
- **Control via built-in web server to remotely access all HMI functions via a PC with alarm notification via email alerts**
- **Communication gateway for other protocols (option 149)**
BACnet/IP communication gateway
Factory-fitted bi-directional communication using the BACnet over Ethernet IP network protocol. This option is used to integrate the machine into a BACnet IP centralised building management system.

SPECIFICATION GUIDE

Volt-free contacts available as standard for remote control of the machine

■ Inputs

- Automatic operation control: switches machine on/off
- Automatic operation control: switches machine on/off
- Heating/cooling operating mode selection
- Selection of setpoint 1/setpoint 2: activates a second setpoint
- Setpoint offset (4-20 mA signal to offset the active setpoint of the unit)
- Condenser flow switch
- Power limitation(4-20mA to set demand limit): allows the power or refrigerating consumption of the machine to be limited by stopping one or more compressors (this limit can be set with a parameter)
- End of storage signal: enables return to the second setpoint at the end of the storage cycle
- User fault reporting
- Customer interlock (open=unit shuts down / closed = enable to operate)
- Time schedule override: cancels the time schedule

■ Outputs

- Alarm relay (report alarm state)
- Operational status reporting: indicates that the unit is in production mode by 0-10V command)
- Alert reporting: this contact indicates the presence of a minor fault which has not caused the affected circuit to stop
- Fault reporting: indicates the presence of a major fault which has caused one or both refrigerating circuits to stop
- Power indication: analogue output (0-10 V) providing an indication of the machine's load rate
- Compressor status

• Master/slave operation (Option 58A)

Unit equipped with an additional leaving water temperature sensor to be fitted on site, to optimise the operation of two units with operating time balancing

Frame and casing

The machine chassis must include heat exchangers and compressors in an autonomous structure

The electrical cabinet will be in RAL 7035 light grey

INSTALLATION RECOMMENDATIONS

Water quality requirements

The quality of the water used has a direct impact on the correct operation of the unit and its service life. This holds particularly true if the water used may clog or corrode components or promote the growth of algae or microorganisms.

The water must be tested to determine whether it is suitable for use with the unit.

Determine whether or not chemical treatment is necessary and sufficient to bring the water to an acceptable quality.

The results of the test must confirm whether the water is compatible with the materials used on the unit's circuit.

Important: failure to follow these instructions will result in the immediate voiding of the unit warranty.

Lifting and handling operations

The utmost safety precautions must be taken when lifting and handling the unit.

Always follow the lifting diagram on the unit and in the installation, operation, commissioning and maintenance manual.

Before attempting to lift the unit, make sure the path leading to its intended location is free from obstacles.

Always keep the unit vertical when moving it. Never tip it or place it on its side.

Location

19PV units are designed for installation inside equipment rooms.

Precautions should be taken to protect it from freezing temperatures. Special attention should be paid to ensure sufficient free space (including at the top) to allow maintenance.

The unit must be placed on a perfectly level surface strong enough to support it once ready for operation.

Noise pollution from auxiliary equipment such as pumps should be studied thoroughly.

Potential noise transmission routes should be studied, with assistance from an acoustical engineer if necessary, before installing the unit.

Flexible couplings must be placed over pipes (available as options).

Machine room ventilation

Local regulations may require a supply of fresh air inside equipment rooms to prevent the build-up of unpleasant or hazardous vapours in the event of a refrigerant leak.

Installation of accessories delivered separately

A number of optional accessories may be delivered separately and installed on the unit at its location.

Always follow the instructions in the installation, operation, commissioning and maintenance manual.

Electrical connections

Always follow the instructions in the installation, operation, commissioning and maintenance manual.

All information concerning electrical connections is stated on the wiring diagrams provided with the unit. Always follow this information.

Electrical connections must be made in accordance with best current practices and applicable standards and regulations.

Electrical cable connections to be made on-site:

- the unit's electrical power supply
- contacts available as standard and optional for controlling the machine remotely.

It should be noted that the unit's electrical system is not protected against lightning strikes.

Components to protect against transient voltage surges must be installed on the system and inside the electrical power supply unit.

Pipe connections

Always follow the instructions in the installation, operation, commissioning and maintenance manual.

All pipes must be correctly aligned and slope toward the system's drain valve.

Pipes must be installed to allow sufficient access to the panels and fitted with heat insulation.

Pipe hangers and clamps must be separate to avoid vibrations and placing pressure on the unit.

Water flow shut-off and control valves must be fitted when the unit is installed.

Pipe connections to be made on site:

- water supply with pressure-reducing valve
- evaporator, condenser and drain

The following are a few examples of accessories essential to any hydraulic system and which must also be installed:

- thermostatic valve on the condenser water inlet or outlet to regulate the flow of cooling water.
- water expansion vessel
- drain nozzles at pipe low points
- exchanger shut-off valves equipped with filters
- air vents at pipe high points
- check the system's water capacity (install a buffer water tank if necessary)
- flexible couplings on exchanger inlets and outlets
- thermometers on each water inlet and outlet to allow all the necessary checks during start-up and maintenance.

Important:

- Pressure in the water circuits below 10 bar.
- Place the expansion vessel before the pump.
- Do not place any valves on the expansion vessel.
- Make sure the pressure of the water drawn in by the circulation pumps is greater than or equal to the required minimum NPSH, particularly if the water circuits are open".
- Test the water quality in accordance with the relevant technical requirements.
- Protect the unit and hydraulic system from freezing temperatures (such as by including a drain. If glycol is added to prevent freezing, check its type and concentration beforehand.
- Before making any final hydraulic connections, flush the pipes with clean water to remove any impurities from the system.

INSTALLATION RECOMMENDATIONS

System start-up

CARRIER or a CARRIER-approved firm must perform system start-up on the units.

Always follow the instructions in the installation, operation, commissioning and maintenance manual.

Partial list of precommissioning checks:

- Correct positioning of unit
- Power supply protections
- Phases and direction of rotation
- Wiring connections on unit
- Direction of water circulation in unit
- Cleanliness of water circuit
- Water flow rate at specified value
- Pressure in the refrigerating circuit
- Direction of rotation of compressors
- Water pressure drops and flow rates
- Operating readings

Maintenance

Specific preventive maintenance operations must be regularly performed on the unit by

CARRIER-approved firms.

Read the operating parameters and note them down on a checklist to be sent to CARRIER.

Refer to and follow the installation, operation, commissioning and maintenance manual when doing so.

You must take out a maintenance contract with a CARRIER-approved refrigeration equipment specialist. Such a contract is required even during the warranty period.

DRYCOOLERS

CARRIER's **09PE** and **09VE** dry coolers are compatible with 19PV water-cooled water chillers.

09PE et **09VE** are available in a wide selection of sizes and with various fan speeds to meet the size and acoustic requirements of any site.



COOLING SCHEMATIC INSTALLATION DIAGRAM

Cooling installation with drycooler

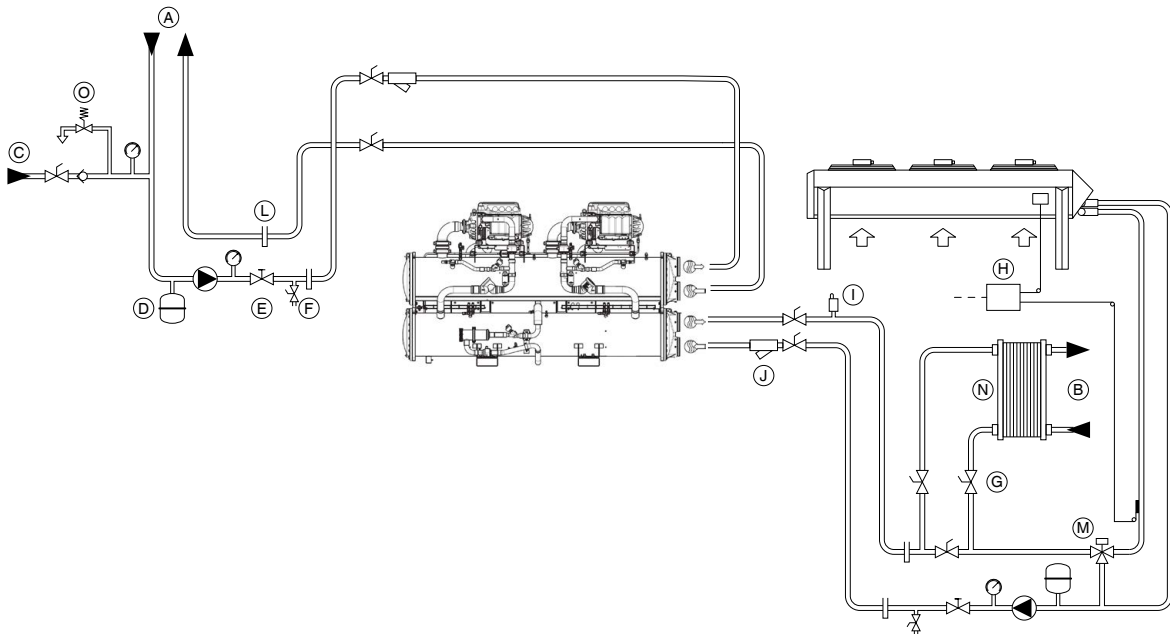

- (A) Chilled water circuit
- (B) Recovery water circuit
- (C) Water supply valve
- (D) Expansion vessel
- (E) Control valve

- (F) Drain
- (G) Shut-off valve
- (H) Temperature controller
- (I) Air bleed valve
- (J) Water filter

- (L) Thermowell
- (M) 3-way hydraulic valve
- (N) Cleanable heat exchanger
- (O) Safety valve

CONTROL

USER-FRIENDLY INTERFACE CONSOLE

- User-friendly 7 inch touchscreen.
- Technical literature include on the controller
- Information displayed in a choice of languages.
- Temperature and pressure readings.
- Operating and fault status diagnostics.
- Master/slave control of two machines in parallel.
- Fault memory management.
- Pump management.
- Time schedule.
- **IP Web server connectivity.**
- Programmable maintenance.
- Preventive maintenance.
- FGAS maintenance.
- **E-mail alerts.**

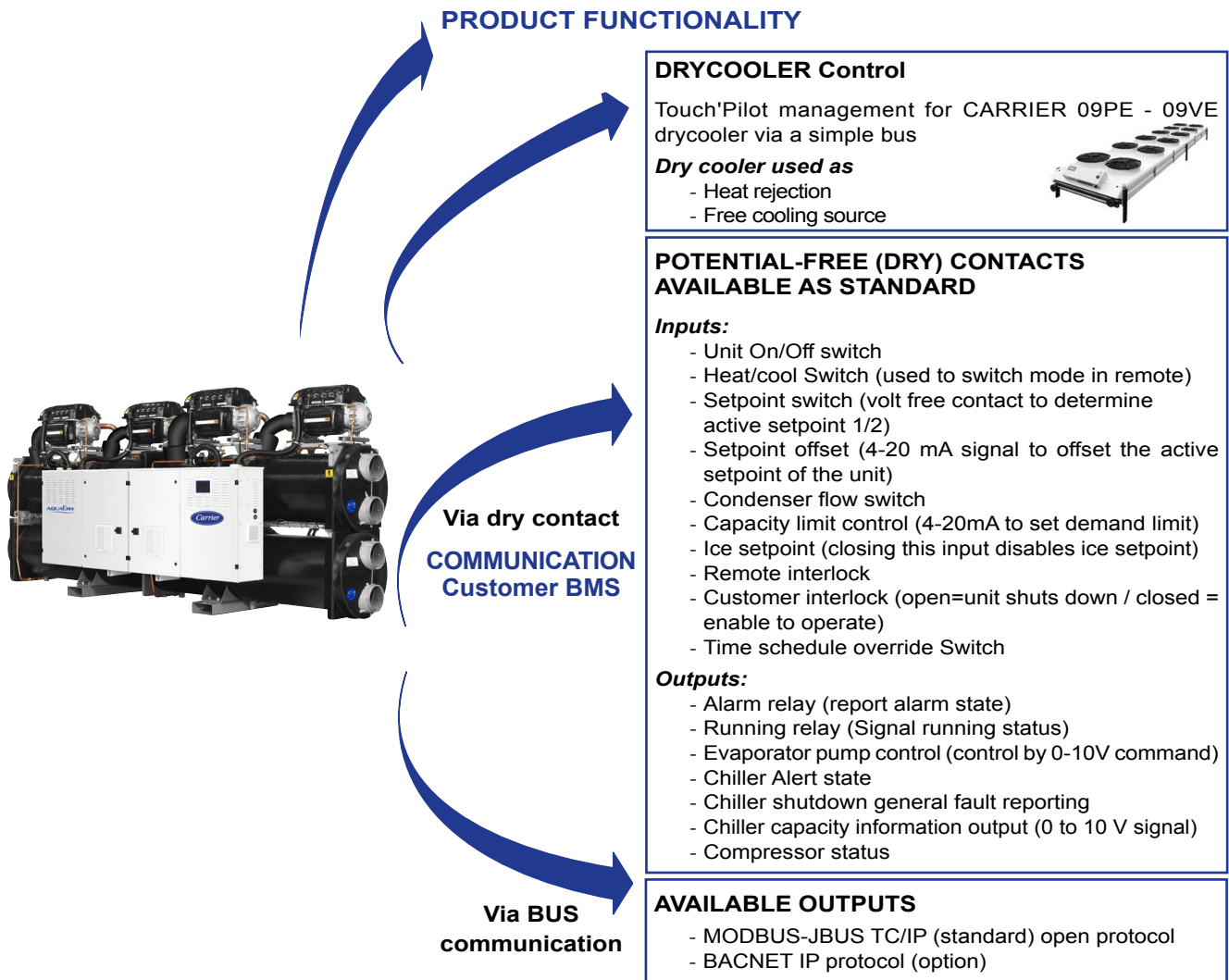
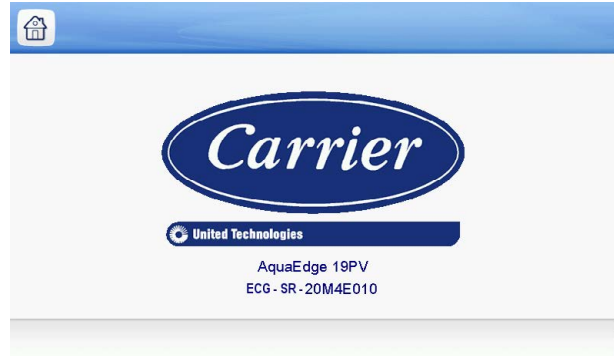



Quality and Environment
Management Systems
Approval



Order No.: 10268, 03.2018. Supersedes order No.: New.
Manufacturer reserves the right to change any product specifications without notice.
The illustrations in this document are for illustrative purposes only and not part of any offer for sale or contract. The manufacturer reserves the right to change the design at any time without notice.

Manufactured by: Carrier SCS, Montluel, France.
Printed in the European Union.