



## PRODUCT SELECTION DATA

### AIR-COOLED SCROLL CHILLERS WITH GREENSPEED® INTELLIGENCE



Unit with low noise level option

High full-load and part-load efficiency

Compact and simple to install

Low sound level

Low refrigerant charge

Superior reliability

## 30RBM/30RBP 160-520



Nominal cooling capacity 164-528 kW

AquaSnap® liquid chillers are the best solution for commercial and industrial applications where installers, engineering and design departments and building owners require reduced installation costs, optimal performance and the highest quality.

The new generation of AquaSnap liquid chillers feature two new versions:

- The AquaSnap (30RBM) version features a compact all-in-one package optimised for full-load applications where reduced investment cost (low CapEx) is required. For cold or hot climates, the AquaSnap can be equipped with specific options to operate from -20°C up to +52°C.
- The AquaSnap Greenspeed® (30RBP) version is a compact all-in-one package optimised for part-load applications where high ESEER, SEPR and IPLV are required. The AquaSnap Greenspeed®, equipped with a variable speed pump and fans, provides premium part-load efficiency to reduce maintenance costs over the lifespan of the chiller. Additionally, the low sounds levels achieved at part load conditions can be very beneficial for sensitive acoustic applications. Besides operating efficiently and quietly, the AquaSnap Greenspeed® operates from -20°C up to +48°C as standard.



CARRIER participates in the ECP programme for LCP/HP  
Check ongoing validity of certificate:  
[www.eurovent-certification.com](http://www.eurovent-certification.com)

# AQUASNAP WITH GREENSPEED INTELLIGENCE

## SIMPLICITY

The simplicity of AquaSnap, tried and trusted

### ■ Experience

With more than 60,000 units installed since 1998, AquaSnap is the **reference standard in “plug & play”** air conditioning solutions. Compact and simple to install, the new AquaSnap with Greenspeed intelligence combines trusted reliability with even more innovation.

### ■ Easy installation

AquaSnap integrates an hydronic module with pressure transducers for digital water flow rate display on the user interface and pump protection against low hydraulic pressure.

The **variable-speed pump allows easy and fast installation start-up** thanks to the electronic setting of the nominal water flow.

### ■ Adaptability

The AquaSnap can operate in all climates from -20°C to +52°C. Thanks to special coil coatings and reinforced electrical protections, the AquaSnap can withstand operation **in corrosive and dusty environments**. To match specific industrial or commercial application requirements, the unit can be equipped with **multiple options**.

REFERENCE IN  
«**PLUG & PLAY**»  
AIR CONDITIONING  
SOLUTIONS

UP TO 15% MORE  
EFFICIENCY WITH THE SAME  
DIMENSIONS AS PREVIOUS  
GENERATION

ONE PRODUCT  
FOR MANY  
APPLICATIONS

&

## INTELLIGENCE

Greenspeed intelligence: the smart innovation

### ■ Smart efficiency

The new generation of AquaSnap chillers delivers on the energy savings and reduced carbon footprint required by the latest European regulations. AquaSnap with Greenspeed intelligence offers Class A or B energy efficiency ratings and Eurovent **Seasonal Energy Efficiency (SEER) of up to 4.53**, making it the best value air conditioning solution in commercial and industrial applications.

### ■ Acoustic comfort

Thanks to the variable-speed fans, AquaSnap with Greenspeed intelligence offers **smooth fan speed variation during partial load operation**. For noise sensitive environments during night and day, the AquaSnap noise level can be automatically factory-set or tuned on-site.

### ■ Advanced control

An advanced control algorithm calculates the energy efficiency and **readjusts in real-time** the fan speed to reduce the cooling energy use. For further energy savings, the water flow rate can be **electronically controlled** to meet real application needs and thus reduce significantly the pumping energy use during night and day.

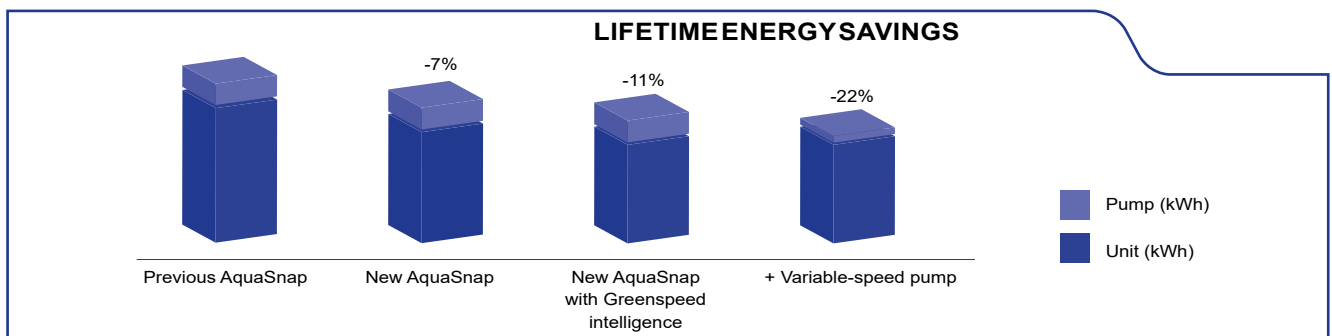

15-year energy savings calculations comparing a 400kW AquaSnap unit of the previous generation to a new AquaSnap unit, a new AquaSnap Greenspeed unit with variable speed pump at an office building in an average European climate, 1500 running hours and 500 stand-by hours per year. This information is intended as an example for comparison purposes only.

# 30RBM TECHNICAL INSIGHT

## AquaSnap scroll chillers 30RBM

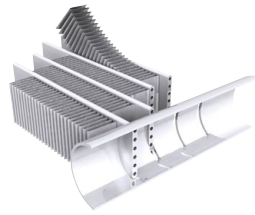

### NOVATION® MICROCHANNEL

- Up to 50% refrigerant charge reduction vs. traditional Cu/Al coils\*
- Better thermal performance, better efficiency and lower air pressure drop vs. Cu/Al coils
- Enviro-Shield® and Super Enviro-Shield® coatings, as options, for mild and severe corrosive environments

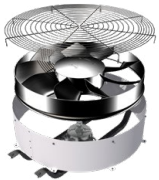

**FIXED-SPEED FLYING BIRD® FAN**

**SCROLL COMPRESSORS**



### SmartVu™ CONTROL

- 4.3" user-friendly touch screen
- All main parameters displayed on one screen
- Direct access to the unit's technical drawings and main service documents
- Easy remote monitoring via the internet
- Easy and secured access to unit parameters

**REDUCED REFRIGERANT CHARGE**

**HIGH EFFICIENCY BRAZED PLATE HEAT EXCHANGER**



# 30RBP TECHNICAL INSIGHT

## AquaSnap scroll chillers with Greenspeed intelligence 30RBP



**FAN VARIABLE-SPEED DRIVE**

**VARIABLE-SPEED FLYING BIRD® FAN**

- Carrier-designed fan blades
- Proprietary algorithm to control fan speed
- Dedicated drive
- Night-mode operation

**VARIABLE-SPEED PUMP (OPTION)**

- Water flow electronic setting & readings
- Automatic pump protection against low water pressure
- Multiple pump control capabilities:
  - fixed-speed
  - variable-speed based on constant pressure or constant temperature

**PUMP VARIABLE-SPEED DRIVE**

## FEATURES AND BENEFITS

AquaSnap liquid chillers are designed to meet current and future Ecodesign and F-Gas European regulation requirements in terms of energy efficiency and reduced CO<sub>2</sub> emissions.

They use the best technologies available today:

- Reduced refrigerant charge of ozone-friendly refrigerant R-410A
- Scroll compressors
- Greenspeed® variable-speed fans (30RBP models)
- Novation® micro-channel heat exchangers with a new aluminium alloy
- Brazed-plate heat exchangers with reduced pressure drops
- Auto-adaptive microprocessor control with Greenspeed® intelligence
- Colour touch screen with web connectivity options
- Extra energy savings through multiple options: direct-expansion free-cooling system on one or two circuits, partial heat recovery.

Both Aquasnap versions can be equipped with a built-in hydraulic module, limiting the installation to conventional operations such as connection of the power supply and the supply and return piping (plug & play), according to the dimensions of the standard unit.

Recommended by Carrier, Aquasnap can be equipped with one or two Greenspeed® variable-speed pumps to significantly reduce energy costs linked to pumping (reduction of more than two-thirds), ensure optimum water flow rate control, and improve overall system reliability.

For use in the harshest environments combining high temperatures, dust and sand, the AquaSnap (30RBM) can be equipped with an optional IP54 electrical box and cabinet fan enabling it to operate at outdoor air temperatures of up to 52°C.



### Very economical operation

- High unit full- and part-load energy efficiency and efficient design of the water side:
  - Eurovent energy efficiency class A or B
  - SEER<sub>12/7°C</sub> of up to 4.7 (30RBP version) in line with the new Ecodesign 2016/2281 regulations
  - Multiple scroll compressors equipped with a high-efficiency motor which can exactly match the cooling capacity to the load required
  - Electronic expansion valve permitting operation at a lower condensing pressure and improved utilisation of the evaporator heat exchange surface (superheat control)

- Condenser with high-efficiency Novation® aluminium micro-channel heat exchangers and Greenspeed® variable-speed fans (30RBP version)
- Low pressure drop brazed plate heat exchangers (< 45 kPa under Eurovent conditions).

- Specific control functions to reduce unit cooling energy use during occupied and unoccupied periods:
  - Internal timer: switches the chiller on/off and controls operation at a second setpoint
  - Setpoint automatically offset based on the outside air temperature or room air temperature (via an option)
  - Floating high pressure management
  - Variable-speed fan control
  - Cooling demand limitation.

Refer to control chapter for more information.

- Greenspeed® variable-speed pump to reduce pumping energy consumption by up to two-thirds (option recommended by Carrier):
  - Eliminate energy losses through the water flow control valve by electronically setting the nominal water flow
  - Save energy during stand-by periods or part-load operation by automatically reducing the water pump speed. The energy consumption of the pump motor varies according to the cube of the speed, so that a reduction in speed of just 40% can reduce energy consumption by 80%
  - Improved unit part-load performance (Increased SEER value with variable water flow according to EN14825 standard).

Refer to the hydraulic option chapter for more information.



- Extra energy savings through multiple options:
  - Direct expansion free-cooling without glycol (Carrier patented) on one or two refrigerating circuits
  - Partial heat recovery.
- Reduced maintenance costs:
  - Fast diagnosis of possible incidents and their history via the control
  - R-410A refrigerant is easier to use than other refrigerant blends.

## FEATURES AND BENEFITS

### Low sound level

- Condenser with fixed-speed fans (30RBM models):
  - Optional low-speed fans (700 rpm) and compressor enclosure to reduce full-load noise level by 6 to 7 dB(A)
  - Condenser coils in V-shape with an open angle, allowing quieter air flow across the coil
  - Low-noise 4<sup>th</sup> generation Flying Bird fans, made of a composite material (Carrier patent)
  - Rigid fan installation for reduced noise (Carrier patent).
- Condenser with Greenspeed® variable-speed fans (30RBP models recommended by Carrier for even quieter operation):
  - Optional factory setting of the fan to low speed, with compressor enclosure to reduce full-load noise level by 6 to 7 dB(A)
  - Exceptional acoustic signature during part-load operation through smooth fan speed variation.
- Specific control functions or features to reduce noise level during the night or unoccupied periods:
  - Night-time sound control with cooling capacity and fan speed limitation
  - Low-noise scroll compressors with low vibration level
  - The compressor assembly is installed on an independent chassis and supported by flexible anti-vibration mounts
  - Dynamic suction and discharge piping support, minimising vibration transmission (Carrier patent)
  - Acoustic compressor enclosure, reducing noise emissions (optional).



### Quick and easy installation

- Compact design:
  - AquaSnap units are designed with compact dimensions for easy installation.
  - With a length of approximately 4.8 m for 520 kW and a width of 2.25 m, the units require minimal floor space.
- Integrated hydronic module (optional):
  - Low or high-pressure water pump (as required)
  - Single or dual pump (as required) with operating time balancing and automatic changeover to the back-up pump if a fault develops

- Water filter protects the water pump against circulating debris
- Pressure transducers for direct numerical display of the water flow rate and water pressures
- Thermal insulation and frost protection down to -20°C, using a heater (optional)
- High-capacity membrane expansion tank (option).
- Built-in hydraulic module with Greenspeed® variable-speed pump (option recommended by Carrier):
  - Quick and easy electronic setting of the nominal water flow rate when the unit is commissioned, thus eliminating the need to adjust the water flow rate control valve
  - Automatic control of the pump speed based on constant speed, constant pressure difference or constant temperature difference.
- Simplified electrical connections
  - A single power supply point without neutral
  - Main disconnect switch with high trip capacity
  - 24 V control circuit using an integrated transformer.
- Fast unit commissioning
  - Systematic factory test before shipment
  - Quick-test function for step-by-step verification of the sensors, electrical components and motors.

### Reduced installation costs

- Optional Greenspeed® variable-speed pump with hydronic module (option recommended by Carrier)
  - Cut costs relating to the water flow control valve
  - The design of the water system with variable primary flow (VPF) can provide significant installation cost savings compared with traditional constant primary systems with variable secondary circuits; elimination of the secondary distribution pump, etc.
  - Water system design with fan coils fitted with 2-way valves instead of 3-way valves.
- No buffer tank required thanks to Carrier's advanced control algorithm
  - Minimum water loop volume reduced to 2.5 l/kW.

### Environmentally responsible

- R-410A ozone-friendly refrigerant.
- Reduced direct warming potential (10% of total equivalent warming impact):
  - Low R410-A refrigerant charge, below 0.14 kg/kW, through the use of Novation® micro-channel heat exchangers
  - Leak-tight refrigerant circuit with minimum brazed connections
  - Qualified Carrier maintenance personnel carry out refrigerant servicing operations
  - ISO14001-certified site of manufacture.
- Reduced indirect warming potential (90% of total equivalent warming impact):
  - Reduced unit energy use (high full- and part-load efficiency)
  - Pumping energy consumption can be reduced by up to 2/3 using Greenspeed® variable-speed pumps.



# FEATURES AND BENEFITS

## Superior reliability

- State-of-the-art concept
  - Two independent refrigerant circuits; the second one automatically takes over, if the first one develops a fault, maintaining partial cooling under all circumstances
  - All compressor components are easily accessible on site minimising down-time
  - All-aluminum Novation® micro-channel heat exchanger (MCHE) with higher corrosion resistance than a conventional coil. The all-aluminum construction eliminates the formation of galvanic currents between aluminum and copper that are responsible for the coil corrosion in saline or corrosive atmospheres.
  - V-coil design to protect the coils against hail impact
  - Optional Enviro-shield anti-corrosion coil coating for use in moderately corrosive environments. Coating applied through conversion process which modifies the surface of the aluminum producing a coating that is integral to the coil. Complete immersion in a bath to ensure 100% coverage. No heat transfer variation, tested 4000 hours salt spray per ASTM B117.
  - Optional Super Enviro-shield anti-corrosion coil coating for use in extremely corrosive environments. Extremely durable and flexible epoxy polymer coating applied on micro channel heat exchangers by electro coating process with a final UV protective topcoat. Minimal heat transfer variation, tested 6000 hours constant neutral salt spray per ASTM B117, superior impact resistance per ASTM D2794.
  - Optional IP54 protection level of compressor control boxes and cabinet fan to guarantee safe operation in hot, dusty, sandy environments
  - Electronic flow switch. Auto-setting according to cooler size and fluid type.
- Auto-adaptive control
  - Control algorithm prevents excessive compressor cycling and permits reduction of the water quantity in the water loop (Carrier patent)
  - Automatic compressor unloading in case of abnormally high condensing pressure
  - Automatic fan speed adjustment in case of coil fouling (30RBP models)
  - Smooth fan start to increase unit lifetime (30RBP models).
- Exceptional endurance tests
  - Partnerships with specialised laboratories and use of limit simulation tools (finite element calculation) for the design of critical components
  - Transport simulation test on an endurance circuit based on a military standard.

## SmartVu™ control

The SmartVu™ control combines intelligence with operating simplicity. The control constantly monitors all machine parameters and precisely manages the operation of compressors, expansion devices, fans and of the evaporator water pump for optimum energy efficiency.

The SmartVu™ control features advanced communication technology over Ethernet (IP), and a user-friendly and intuitive user interface with 5-inch colour touch screen.

- Energy management configuration
  - Internal timer: controls chiller on/off times and operation at a second setpoint
  - Setpoint offset based on the outside air temperature
  - Master/slave control of two chillers operating in parallel with runtime balancing and automatic changeover in case of a unit fault.
  - Innovative smart energy monitoring, providing users with smart data such as real time electric energy consumption, cooling capacity, and instantaneous and average seasonal energy efficiency ratios.
- Integrated features
  - Night mode: Capacity and fan speed limitation for reduced noise level
  - With hydronic module: Water pressure display and water flow rate calculation.
- Advanced communication features
  - Easy and high-speed communication technology over Ethernet (IP) to a centralised building management system
  - Access to multiple unit parameters.
- Maintenance functions
  - F-Gas regulation leak check reminder alert
  - Maintenance alert can be configured to days, months or hours of operation
- 4”3-inch SmartVu™ user interface



- Intuitive and user-friendly 4”3 inch touch screen interface
- Concise and clear information is available in local languages
- Complete menu, customised for different users (end user, service personnel or Carrier engineers).

## FEATURES AND BENEFITS

---

### Remote management (standard)

Units with SmartVu™ control can be easily accessed from the internet, using a PC with an Ethernet connection. This makes remote control quick and easy and offers significant advantages for service operations.

The Aquasnap is equipped with an RS485 serial port that offers multiple remote control, monitoring and diagnostic possibilities. Carrier offers a vast choice of control products, specially designed to control, manage and supervise the operation of an air conditioning system. Please consult your Carrier representative for more information.

The Aquasnap also communicates with other centralised building management systems via optional communication gateways.

A connection terminal allows remote control of the Aquasnap unit by wired cable:

- Start/stop: Opening of this contact will shut down the unit
- Dual setpoint: closing of this contact activates a second setpoint (e.g.: unoccupied mode).
- Demand limit: Closing of this contact limits the maximum chiller capacity to a predefined value.
- Operation indication: This volt-free contact indicates that the chiller is operating (cooling load).
- Alarm indication: this volt-free contact indicates the presence of a major fault that has led to the shut-down of one or several refrigerant circuits.
- Pump control: 0/10V signal to control external variable speed pump

### Energy management module (optional)

The Energy Management Module offers extended remote control possibilities:

- Room temperature: enables the setpoint to be reset based on the indoor air temperature of the building (with Carrier thermostat).
- Setpoint reset: the cooling setpoint is reset based on a 4-20 mA signal.
- Demand limit: Enables the maximum chiller power to be limited based on a 4-20 mA signal.
- Demand limit 1 and 2: Closing of these contacts limits the maximum chiller power or current to two predefined values.
- User safety: This contact can be used for any customer safety loop; opening the contact generates a specific alarm.
- Ice storage end: when ice storage has finished, this input is used to return to the second setpoint (unoccupied mode).
- Timer override: closing of this contact cancels the effects of the timer.
- Out of service: This signal indicates that the chiller is completely out of service.
- Chiller capacity: This analogue output (0-10 V) gives an immediate indication of the chiller capacity.
- Alert indication: this volt-free contact indicates the necessity to carry out a maintenance operation or the presence of a minor fault.
- Boiler control: this on/off output controls an independent boiler to provide hot water.

### Novation® Aluminium micro-channel heat exchanger



The Novation® is the latest generation of Carrier Micro-Channel Heat Exchanger (MCHE) with a new, extra-resistant aluminium alloy. Already used in the automotive and aeronautical industries for many years, the micro-channel heat exchanger (MCHE) on the AquaSnap is made entirely of aluminium. This one-piece concept significantly increases its corrosion resistance by eliminating the galvanic currents that are created when two different metals (copper and aluminium) come into contact in conventional heat exchangers. Unlike traditional heat exchangers, MCHEs can be used in moderate marine and urban environments.

In terms of energy efficiency, MCHEs are approximately 10% more efficient than a traditional coil and enable a 40% reduction in the amount of refrigerant used in the chiller. The slim design of the MCHE reduces air pressure losses by 50% and, compared to a traditional coil, makes it less susceptible to fouling (e.g. by sand). The MCHE can be cleaned very quickly using a high-pressure washer.



## OPTIONS

Options	No.	Description	Advantages	Use
Medium-temperature brine solution	5B	Low temperature chilled water production down to 0°C with ethylene glycol and propylene glycol.	Covers specific applications such as ice storage and industrial processes	30RBM/30RBP 160-520
Low-temperature brine solution	6B	Low temperature chilled water production down to -15°C with ethylene glycol and -12°C with propylene glycol.	Covers specific applications such as ice storage and industrial processes	30RBM/P 160-400 for chilled water down to -15°C
High pressure static fans	12	Unit equipped with high pressure static variable-speed fans (maximum 200 Pa), each fan being equipped with a connection flange for connection to the ducting system.	Ducted fan discharge, optimised condensing temperature (or evaporating temperature on Heat pump version) control, based on the operating conditions and system characteristics	30RBP160-520
Low noise level	15	Aesthetic and sound absorbing compressor enclosure	Noise level reduction by 1 to 2 dB(A)	30RBM/30RBP 160-520
Very low noise level	15LS	Acoustic compressor enclosure and low-speed fans	Noise level reduction by 6 to 7 dB(A)	30RBM/30RBP 160-520
High ambient temperature	16	Unit equipped with electrical panel cooling fan	Extended unit part-load operation up to 52°C ambient temperature	30RBM 160-520
IP54 control box	20A	Increased leak tightness of the unit	Protects the inside of the control panel from dust, water and sand. As a rule, this option is recommended for installations located in polluted environments	30RBM/30RBP 160-520
Grilles and enclosure panels	23	Metal grilles on the 4 sides of the unit, plus side enclosure panels at each end of the coil	Improves aesthetics, protection against intrusion to the unit interior, coil and piping protection against impacts.	30RBM/30RBP 160-520
Enclosure panels	23A	Side enclosure panels at each end of the coil	Improved aesthetics, coil and piping protection against impacts.	30RBM/30RBP 160-520
Soft starter	25	Electronic starter on each compressor	Reduced start-up current	30RBM/30RBP 160-520
Winter operation down to -20°C	28	Fan speed control of lead fan for each circuit using a variable frequency drive	Stable unit operation for outside air temperatures from 0°C down to -20°C in cooling mode	30RBM 160-520
Winter operation down to -10°C	28B	Two-speed lead fan for each circuit	Stable unit operation for outside air temperature from 0°C down to -10°C	30RBM 160-520
Winter operation down to -10°C low speed	28C	Two Low speed fans on lead fan on each circuit	Reduces the noise level and enables stable unit operation for outside air temperatures down to -10°C	30RBM 160-520
Water exchanger frost protection	41	Electric heater on the water exchanger and the water piping	Water exchanger module frost protection between 0°C and -20°C outside air temperature	30RBM/30RBP 160-520
Exchanger & hydraulic frost protection	42A	Electric heater on the water exchanger hydraulic module and optional expansion tank	Water exchanger and hydraulic module frost protection between 0°C and -20°C outside air temperature	30RBM/30RBP 160-520
Partial heat recovery	49	Unit equipped with one desuperheater on each refrigerant circuit	Production of free high-temperature hot-water simultaneously with chilled water production (or hot water for Heat pump)	30RBM/30RBP 160-520
Shell and tube evaporator aluminium insulation	88	Evaporator covered with an aluminum sheet for thermal insulation protection	Improved resistance to aggressive climate conditions	30 RBM/RBP 160-260
Master/slave operation	58	Unit equipped with supplementary water outlet temperature sensor kit (to be field installed) allowing master/slave operation of two units connected in parallel	Optimised operation of two units connected in parrallel operation with operating time equalisation	30RBM/30RBP 160-520
Compressor suction and discharge valves	92A	Shut-off valves on the compressor suction and discharge piping	Simplified maintenance. Possibility to store the refrigerant charge in the cooler or condenser side during servicing	30RBM/30RBP 160-520
Compressor discharge valves	93A	Shut-off valves on the compressor common discharge piping	Simplified maintenance. Possibility to store the refrigerant charge in the condenser side during servicing	30RBM/30RBP 160-520
HP single-pump hydraulic module	116R	Single high-pressure water pump, water filter, electronic water flow control, pressure transducers. For more details, refer to the dedicated chapter (expansion tank not included; Option with built-in safety hydraulic components available.)	Easy and fast installation (plug & play)	30RBM/30RBP 160-400

## OPTIONS

Options	No.	Description	Advantages	Use
HP dual-pump hydraulic module	116S	Dual high-pressure water pump, water filter, electronic water flow control, pressure transducers. For more details, refer to the dedicated chapter (expansion tank not included); Option with built-in safety hydraulic components available)	Easy and fast installation (plug & play)	30RBM/30RBP 160-400
LP single-pump hydronic module	116T	Single low-pressure water pump, water filter, electronic water flow control, pressure transducers. For more details, refer to the dedicated chapter (expansion tank not included); Option with built-in safety hydraulic components available)	Easy and fast installation (plug & play)	30RBM/30RBP 160-400
LP dual-pump hydraulic module	116U	Dual low-pressure water pump, water filter, electronic water flow control, pressure transducers. For more details, refer to the dedicated chapter (expansion tank not included); Option with built-in safety hydraulic components available)	Easy and fast installation (plug & play)	30RBM/30RBP 160-400
HP evap. variable-speed single-pump	116V	Single high-pressure water pump with variable speed drive (VSD), water filter, electronic water flow control, pressure transducers. Multiple possibilities of water flow control. For more details, refer to the dedicated chapter (expansion tank not included; Option with built-in safety hydraulic components available)	Easy and fast installation (plug & play), significant pumping energy cost savings (more than two-thirds), tighter water flow control, improved system reliability	30RBM/30RBP 160-520
HP VSD dual-pump hydraulic mod.	116W	Dual high-pressure water pump with variable speed drive (VSD), water filter, electronic flow switch, pressure transducers. Multiple possibilities of water flow control. For more details, refer to the dedicated chapter (expansion tank not included; Option with built-in safety hydraulic components available)	Easy and fast installation (plug & play), significant pumping energy cost savings, tighter water flow control, improved system reliability	30RBM/30RBP 160-520
DX Free-cooling system on two circuits	118A	Patented Carrier free-cooling system with cooling micro-pump on both refrigerant circuits. Operation without glycol, no extra free-cooling coil. See DX Free-cooling option chapter	Energy savings for applications with cooling demand throughout the entire year	30RBM/30RBP 220-520
DX Free-cooling system on one circuit	118B	Patented Carrier free-cooling system with cooling micro-pump on one refrigerant circuit. Operation without glycol, no extra free-cooling coil. See DX Free-cooling option chapter	Energy savings for applications with reduced demand for cooling in winter (e.g. offices with a computer room, meeting rooms etc.)	30RBM/30RBP 160-520 Not available on 30RBP 360/400
Lon gateway	148D	Bi-directional communication board complying with Lon Talk protocol	Connects the unit by communication bus to a centralised building management system	30RBM/30RBP 160-520
BACnet/IP	149	Bi-directional high-speed communication using BACnet protocol over Ethernet network (IP)	Easy and high-speed connection by ethernet line to a building management system. Allows access to multiple unit parameters	30RBM/30RBP 160-520
Modbus over IP and RS485	149B	Bi-directional high-speed communication using Modbus protocol over Ethernet network (IP)	Easy and high-speed connection by ethernet line to a building management system. Allows access to multiple unit parameters	30RBM/30RBP 160-520
Energy Management Module	156	EMM Control board with additional inputs/outputs. See Energy Management Module option chapter	Extended remote control capabilities (Set-point reset, ice storage end, demand limits, boiler on/off command...)	30RBM/30RBP 160-520
Input contact for Refrigerant leak detection	159	0-10 V signal to report any refrigerant leakage in the unit directly on the controller (the leak detector itself must be supplied by the customer)	Immediate customer notification of refrigerant losses to the atmosphere, allowing timely corrective actions	30RBM/RBP 160-520
Compliance with Russian regulations	199	EAC certification	Compliance with Russian regulations	30RBM/30RBP 160-519
Enviro-Shield anti-corrosion protection	262	Coating by conversion process which modifies the surface of the aluminium producing a coating that is integral to the coil. Complete immersion in a bath to ensure 100% coverage. No heat transfer variation, salt spray resistance test for 4000 hours (ASTM B117)	Improved corrosion resistance, recommended for use in moderately corrosive environments	30RBM/30RBP 160-520

## OPTIONS

Options	No.	Description	Advantages	Use
Super Enviro-Shield anti-corrosion protection	263	Extremely durable and flexible epoxy polymer coating applied on micro channel heat exchangers by electro coating process, final UV protective topcoat. Minimal heat transfer variation, tested 6000 hours constant neutral salt spray per ASTM B117, superior impact resistance per ASTM D2794	Improved corrosion resistance, recommended for use in extremely corrosive environments	30RBM/30RBP 160-520
Welded evaporator connection kit	266	Victaulic piping connections with welded joints	Easy installation	30RBM/30RBP 160-520
Shell and tubes heat exchanger	280	Brazed plate heat exchanger replaced by shell & tube heat exchanger	Extension of the water flow rate range, improved resistance to fouling	30RBM/RBP 160-260
230 V electric plug	284	230 VAC power supply source provided with plug socket and transformer (180 VA, 0.8 A)	Permits connection of a laptop or an electrical device during unit commissioning or servicing	30RBM/30RBP 160-520
Expansion tank	293	6-bar expansion tank integrated into the hydronic module (option 116 required)	Easy and fast installation (plug & play), & Protection of closed water systems from excessive pressure	30RBM/30RBP 160-520
Screwed water connection sleeve kit for DSH	303	DSH connections with screw connection sleeves	Easy installation. Allows unit connection to a screw connector	30RBM/30RBP 160-520
Welded water connection kit for DSH	304	DSH inlet/outlet welded connection sleeves	Easy installation	30RBM/30RBP 160-520
Set point adjustment by 4-20mA signal	311	Connections to allow a 4-20mA signal input	Easy energy management, allow to adjust set point by a 4-20mA external signal	30RBM/30RBP 160-520
Free Cooling dry cooler management	313	Control & connections to a Free Cooling Drycooler 09PE or 09VE fitted with option FC control box	Easy system management, Extended control capabilities to a drycooler used in Free Cooling mode	30RBM/30RBP 160-520
Compliance with UAE regulation	318	Additional label on the unit with rated power input, rated current and EER following AHRI 550/590	Compliance with ESMA standard UAE.S 5010-5:2019.	30RBM/30RBP 160-520
Compliance with Qatar regulation	319	Specific nameplate on the unit with power supply 415 V +/-6%	Compliance with KAHRAMAA regulation in Qatar.	30RBM/30RBP 160-520
Compliance with Morocco regulation	327	Specifics documents according Morocco regulation	Conformance with Morocco regulations	30RBM/RBP 160-520
Plastic tarp	331	Plastic tarp covering units with strapping and camped on the wooden pallet.	Allow unit to avoid dust and dirt from the outside environment during stocking and shipping.	30RBM/RBP 160-520

## PHYSICAL DATA, SIZES 160 TO 520

30RBP			160	180	200	220	260	300	330	360	400	430	470	520	
<b>Cooling</b>															
<b>Standard unit</b> Full load performances*	CA1	Nominal capacity	kW	168	180	197	216	261	300	331	365	397	430	464	523
		EER	kW/kW	3,04	3,12	2,98	2,97	2,90	2,97	2,92	2,95	2,90	2,94	2,90	2,90
	CA2	Nominal capacity	kW	216	247	263	297	336	393	428	475	510	556	593	676
		EER	kW/kW	3,6	3,89	3,59	3,7	3,37	3,53	3,4	3,47	3,37	3,45	3,34	3,38
<b>Standard unit</b> Seasonal energy efficiency**	<b>SEER<sub>12/7°C</sub> Comfort low temp.</b>		kWh/kWh	<b>4,32</b>	<b>4,29</b>	<b>4,18</b>	<b>4,25</b>	<b>4,20</b>	<b>4,52</b>	<b>4,40</b>	<b>4,52</b>	<b>4,37</b>	<b>4,67</b>	<b>4,70</b>	<b>4,65</b>
	<b>ηs cool<sub>12/7°C</sub></b>		%	<b>170</b>	<b>169</b>	<b>164</b>	<b>167</b>	<b>165</b>	<b>178</b>	<b>173</b>	<b>178</b>	<b>172</b>	<b>184</b>	<b>185</b>	<b>183</b>
	<b>SEPR<sub>12/7°C</sub> Process high temp.</b>		kWh/kWh	<b>5,43</b>	<b>5,61</b>	<b>5,32</b>	<b>5,56</b>	<b>5,16</b>	<b>5,60</b>	<b>5,24</b>	<b>5,62</b>	<b>5,32</b>	<b>5,50</b>	<b>5,38</b>	<b>5,26</b>
<b>Unit + option 6</b> Seasonal energy efficiency**	<b>SEPR<sub>-2/-8°C</sub> Process medium temp. ***</b>		kWh/kWh	<b>3,03</b>	<b>3,40</b>	<b>3,38</b>	<b>3,33</b>	<b>3,22</b>	<b>3,40</b>	<b>3,06</b>	<b>3,47</b>	<b>3,42</b>	NA	NA	NA
Part Load integrated values	IPLV.SI		kW/kW	4,758	4,855	4,733	4,849	4,749	4,999	4,833	5,004	4,815	4,925	4,999	4,839
<b>Sound levels</b>															
<b>Standard unit</b>															
Sound power <sup>(3)</sup>	dB(A)		91	92	92	92	92	93	93	93	93	94	94	94	
Sound pressure level at 10 m <sup>(4)</sup>	dB(A)		59	60	60	60	60	60	60	61	61	62	62	62	
<b>Standard unit + option 15<sup>(1)</sup></b>															
Sound power <sup>(3)</sup>	dB(A)		89	90	90	90	90	91	91	92	92	93	93	93	
Sound pressure at 10 m <sup>(4)</sup>	dB(A)		57	58	58	58	58	59	59	60	60	61	61	61	
<b>Standard unit + option 15LS<sup>(1)</sup></b>															
Sound power <sup>(3)</sup>	dB(A)		85	85	85	86	86	86	86	87	87	88	88	88	
Sound pressure at 10 m <sup>(4)</sup>	dB(A)		53	53	53	54	54	54	54	55	55	55	55	56	
<b>Dimensions - standard unit</b>															
Length	mm		2410			3604			4797						
Width	mm		2253			2253			2253						
Height	mm		2322			2322			2322						
Length, unit with water buffer tank option	mm		3604			4798			5991						
<b>Operating weight<sup>(2)</sup></b>															
Standard unit	kg		1240	1278	1278	1407	1429	1882	1918	2082	2139	2576	2594	2796	
Standard unit + option 15 <sup>(1)</sup>	kg		1323	1361	1361	1515	1537	2008	2044	2226	2283	2738	2756	2976	
Standard unit + option 15 + option 116W <sup>(1)</sup>	kg		1462	1500	1500	1655	1692	2168	2248	2429	2486	2980	2997	3257	
Standard unit + option 15 + option 116W + water buffer tank option	kg		2409	2444	2444	2599	2635	3108	3188	3365	3422	3912	3929	4185	

- \* In accordance with standard EN14511-3:2013.  
 \*\* In accordance with standard EN14825:2016  
 \*\*\* With EG 30%  
 CA1 Cooling mode conditions: evaporator water inlet/outlet temperature 12 °C/7 °C, outdoor air temperature 35 °C, evaporator fouling factor 0 m<sup>2</sup>. kW/W  
 CA2 Cooling mode conditions: evaporator water inlet/outlet temperature 23 °C/18 °C, outdoor air temperature 35 °C, evaporator fouling factor 0 m<sup>2</sup>. kW/W  
**ηs cool<sub>12/7°C</sub> & SEER<sub>12/7°C</sub>** **Bold values compliant to Ecodesign regulation: (EU) No 2016/2281 for Comfort application**  
**SEPR<sub>12/7°C</sub>** **Bold values compliant to Ecodesign regulation: (EU) No 2016/2281 for Process application**  
**SEPR<sub>-2/-8°C</sub>** **Bold values compliant to Ecodesign regulation: (EU) No 2015/1095 for Process application**  
 NA Not Authorised for the specific application for the CEE market  
 IPLV.SI Calculations according to standard performances AHRI 551-591 (SI).  
 (1) Options: 15 = Low noise level, 15LS = Very Low Noise level, 116S = High pressure dual-pump hydraulic module  
 (2) Weights are guidelines only. Refer to the unit name plate.  
 (3) In dB ref=10<sup>-12</sup> W, (A) weighting. Declared dual-number noise emission values in accordance with ISO 4871 (with an associated uncertainty of +/-3 dB(A)). Measured in accordance with ISO 9614-1 and certified by Eurovent  
 (4) In dB ref 20μPa, (A) weighting. Declared dual-number noise emission values in accordance with ISO 4871 (with an associated uncertainty of +/-3 dB(A)). For information, calculated from the sound power Lw(A).



Valeurs certifiées Eurovent

## PHYSICAL DATA, SIZES 160 TO 520

30RBP	160	180	200	220	260	300	330	360	400	430	470	520	
<b>Compressors</b>	Hermetic scroll 48,3 tr/s												
Circuit A	1	1	1	2	2	2	2	3	3	3	3	4	
Circuit B	2	2	2	2	2	3	3	3	3	4	4	4	
No. of control stages	3	3	3	4	4	5	5	6	6	7	7	8	
<b>Refrigerant<sup>(2)</sup> - Standard unit</b>	R410A GWP= 2088 (following ARI4)												
Circuit A	kg	8,40	10,90	10,90	12,60	13,10	14,70	15,40	20,30	21,10	23,50	23,50	26,75
	tCO <sub>2</sub> e	17,5	22,8	22,8	26,3	27,4	30,7	32,2	42,4	44,1	49,1	49,1	55,9
Circuit B	kg	12,25	12,60	12,60	12,70	13,10	20,20	20,20	20,40	22,20	26,70	26,80	26,95
	tCO <sub>2</sub> e	25,6	26,3	26,3	26,5	27,4	42,2	42,2	42,6	46,4	55,7	56,0	56,3
<b>Capacity control</b>	SmartVu™ Control												
Minimum capacity	%	33	33	33	25	25	20	20	17	17	14	14	13
<b>Condensers</b>	Aluminium micro-channel coils (MCHE)												
<b>Fans - Standard unit</b>	FLYING BIRD 4 axial fans with rotating impeller												
Quantity	3	4	4	4	4	5	5	6	6	7	7	8	
Maximum total air flow	l/s	13542	18056	18056	18056	18056	22569	22569	27083	27083	31597	31597	36111
Maximum rotation speed	rps	16	16	16	16	16	16	16	16	16	16	16	
<b>Evaporator</b>	Dual-circuit plate heat exchanger												
Water volume	l	15	15	15	15	19	27	35	33	42	44	47	53
Max. water-side operating pressure without hydronic module	kPa	1000	1000	1000	1000	1000	1000	1000	1000	1000	1000	1000	1000
<b>Hydraulic module (option)</b>	Pump, Victaulic screen filter, relief valve, water and air drain valve, pressure sensors, expansion tank (option)												
Pump	Centrifugal pump, monocell, 48,3 r/s, low- or high-pressure (as required), single or dual (as required)												
Expansion tank volume	l	50	50	50	50	80	80	80	80	80	80	80	
Max. water-side operating pressure with hydraulic module	kPa	400	400	400	400	400	400	400	400	400	400	400	
<b>Water connections with/without hydraulic module</b>	Victaulic type												
Diameter	inch	3	3	3	3	3	4	4	4	4	4	4	
External diameter	mm	88,9	88,9	88,9	88,9	88,9	114,3	114,3	114,3	114,3	114,3	114,3	
<b>Casing paintwork</b>	Colour code RAL 7035												

(2) Weights are guidelines only. Refer to the unit name plate.



## ELECTRICAL SPECIFICATIONS

30RBM		160	180	200	220	260	300	330	360	400
<b>Power circuit</b>										
Nominal voltage	V-ph-Hz	400 - 3 - 50								
Voltage range	V	360 - 440								
<b>Control circuit supply</b>										
24 V via internal transformer										
<b>Nominal unit current draw<sup>(1)</sup></b>										
Circuit A&B	A	100	110	124	133	161	180	201	221	242
<b>Max. operating input power<sup>(2)</sup></b>										
Circuit A&B	kW	80	88	99	107	129	145	161	177	194
<b>Cosine Phi unit at maximum power<sup>(2)</sup></b>										
		0,88	0,87	0,87	0,88	0,88	0,88	0,88	0,88	0,88
<b>Maximum unit current draw (Un-10%)<sup>(3)</sup></b>										
Circuit A&B	A	144	158	176	192	230	259	288	317	345
<b>Maximum unit current draw (Un)<sup>(4)</sup></b>										
Circuit A&B - Standard Unit	A	133	146	163	177	212	239	266	292	319
Circuit A&B - Unit with option 231	A	100	110	125	133	163	181	204	222	244
<b>Maximum start-up current, standard unit (Un)†</b>										
Circuit A&B	A	307	356	374	352	423	450	476	503	529
<b>Max. start-up current, unit with soft starter (Un)†</b>										
Circuit A&B	A	261	283	300	305	349	376	403	429	456

(1) Conditions equivalent to the standardised Eurovent conditions (evaporator water input-output temperature = 12 °C/7 °C, outside air temperature = 35 °C)  
(2) Power input, compressors and fans, at the unit operating limits (saturated suction temperature 15°C, saturated condensing temperature 68.3°C) and nominal voltage of 400 V (data given on the unit nameplate).

(3) Maximum unit operating current at maximum unit input power and 360 V.

(4) Maximum unit operating current at maximum unit input power and 400 V (values given on the unit's nameplate).

† Maximum instantaneous start-up current at operating limits (maximum operating current of the smallest compressor(s) + current of the fan(s) + locked rotor current of the largest compressor).

Fan motor electrical data reported upstream the variable speed drive at Eurovent equivalent conditions and motor ambient air temperature of 50°C at 400 V: Current 3.8 A; In-rush current 20 A; Power input: 1.75 kW.

30RBP		160	180	200	220	260	300	330	360	400	430	470	520
<b>Power circuit</b>													
Nominal voltage	V-ph-Hz	400 - 3 - 50											
Voltage range	V	360 - 440											
<b>Control circuit supply</b>													
24 V via internal transformer													
<b>Nominal unit current draw<sup>(1)</sup></b>													
Circuit A&B	A	97	107	121	130	158	176	197	216	237	255	276	316
<b>Cosine Phi unit at maximum power<sup>(2)</sup></b>													
Circuit A&B	kW	81	88	99	108	129	145	162	178	194	210	226	259
<b>Cosine Phi unit at maximum power<sup>(2)</sup></b>													
		0,88	0,88	0,88	0,88	0,88	0,88	0,88	0,88	0,88	0,88	0,88	0,88
<b>Maximum unit current draw (Un-10%)<sup>(3)</sup></b>													
Circuit A&B	A	142	154	173	189	227	255	284	312	340	369	397	454
<b>Maximum unit current draw (Un)<sup>(4)</sup></b>													
Circuit A&B - Standard Unit	A	131	142	160	174	209	235	262	287	314	340	366	419
Circuit A&B - Unit with option 231	A	98	108	123	131	161	178	201	219	241	259	281	321
<b>Maximum start-up current, standard unit (Un)†</b>													
Circuit A&B	A	305	353	371	349	420	446	472	498	525	550	577	629
<b>Max. start-up current, unit with soft starter (Un)†</b>													
Circuit A&B	A	259	279	297	302	346	372	399	424	451	477	503	556

(1) Conditions equivalent to the standardised Eurovent conditions (evaporator water input-output temperature = 12 °C/7 °C, outside air temperature = 35 °C)

(2) Input power, compressors + fans, at the unit operating limits (saturated suction temperature: 15°C, saturated condensing temperature: 68.3°C) and nominal voltage of 400 V (data given on the unit nameplate).

(3) Maximum unit operating current at maximum unit input power and 360 V.

(4) Maximum unit operating current at maximum unit input power and 400 V (values given on the unit's nameplate).

† Maximum instantaneous start-up current at operating limits (maximum operating current of the smallest compressor(s) + current of the fan(s) + locked rotor current of the largest compressor).

Fan motor electrical data reported upstream of the variable drive at Eurovent equivalent conditions and motor ambient air temperature of 50°C at 400 V: Current 3.0 A; Start-up current 20 A; Power input: 1.75 kW.

# ELECTRICAL SPECIFICATIONS

## Short-circuit withstand current (TN system)<sup>(1)</sup>

30RBM/30RBP	160	180	200	220	260	300	330	360	400	430	470	520	
<b>Short time (1s) assigned current I<sub>cw</sub> / Peak current I<sub>pk</sub></b>													
Circuits A&B	kA/kA	8/30	8/30	8/30	8/30	8/30	8/30	8/30	15/65	15/65	15/65	15/65	20/80
<b>With fuses upstream – maximum fuse values assigned (gL/gG)</b>													
Circuits A&B	A	200	200	200	200	250	250	250	315	400	400	400	630
<b>With fuses upstream – assigned conditional short-circuit current I<sub>cc</sub>/I<sub>cf</sub></b>													
Circuits A&B	kA	50	50	50	50	50	50	50	50	50	50	50	50

(1) Type of system earthing

IT system: The short circuit current stability values given above for the TN system are not valid for IT, modifications are required.

### Electrical specifications and operating conditions for 30RBM/30RBP units – Notes

- 30RBM/30RBP units have a single power connection point located immediately upstream of the main disconnect switch
- **The control panel contains:**
  - Main disconnect switch
  - Start-up equipment and motor protection devices for each compressor, the fans, and the pumps,
  - The control devices.
- **Field connections:**  
All connections to the system and the electrical installations must be in accordance with all applicable codes.
- Carrier 30RBM/30RBP units are designed and built to ensure compliance with these codes. The recommendations of European standard EN 60204-1 (corresponding to IEC 60204-1) (Safety of machinery- Electrical equipment of machines - part 1: General requirements) are specifically taken into account, when designing the electrical equipment.

#### Notes

- Generally, the recommendations of IEC 60364 are accepted as compliance with the requirements of the installation regulations.
- Compliance with standard EN 60204-1 is the best means of ensuring compliance (§1.5.1) with the Machinery Directive.
- Appendix B of standard EN 60204-1 specifies the electrical features used for the operation of the machines.
- The operating conditions of 30RBM/30RBP units are described below:
  1. Environment<sup>(1)</sup>  
The classification of environment is specified in standard EN 60364:
    - Outdoor installation<sup>(1)</sup>,
    - Ambient temperature range: from -20 °C to +48 °C<sup>(2)</sup>,
    - Altitude: AC1 lower than or equal to 2000 m (for hydraulic module, see paragraph 4.7 in the IOM)
    - Presence of solid foreign bodies: Class AE3 (no significant dust present)<sup>(1)</sup>,
    - Presence of corrosive and polluting substances, class AF1 (negligible),
    - Competence of personnel: BA4 (trained personnel).
  2. Compatibility for low-frequency conducted disturbances according to class 2 levels as per standard IEC61000-2-4:
    - Power supply frequency variation: +-2Hz
    - Phase imbalance : 2%
    - Total Voltage Harmonic Distortion (THDV): 8%
  3. The neutral wire (N) must not be connected directly to the unit (if necessary use a transformer).
  4. Overcurrent protection of the power supply conductors is not provided with the unit.
  5. The factory-fitted disconnect switch(es)/circuit breaker(s) are of a type suitable for power interruption in accordance with EN 60947-3 (corresponds to IEC 60947-3).

- 6. The units are designed for connection to TN networks (IEC 60364). In IT networks, the use of filters integrated into the frequency inverter(s) prevents the machines from fulfilling their intended purpose. In addition, the equipment characteristics in case of insulation failure are modified. Provide a local earth; consult competent local organisations to complete the electrical installation.  
30RBM/30RBP machines are designed for use in domestic/residential and industrial environments:  
Machines that are not equipped with variable speed drives comply with the standard regulations.
- 61000-6-3: Generic standards - Emission standard for residential, commercial and light-industrial.
- 61000-6-2: General standards - Immunity for industrial environments. Machines that are equipped with variable frequency drive(s) (RBP, options: 28, 116V, 116W) comply with standard EN61800-3 Adjustable speed electrical power drive systems - part 3: EMC requirements and specific test methods for the following classifications:
- Use in the first and second environments<sup>(3)</sup>.
- Category C2 applicable in the first environment, on stationary devices designed to be installed and commissioned by a professional.

**Warning: in a residential environment, this product may cause radio interference which may require additional mitigation measures.**

- Leakage currents: If protection by monitoring the leakage currents is necessary to ensure the safety of the installation, the presence of additional leakage currents introduced by the use of variable frequency drive(s) in the unit must be considered. In particular, these shall be reinforced-immunity protection devices with a threshold not lower than 150 mA.
  - Capacitors that are integrated as part of the option 231 can generate electrical disturbances in the installation the unit is connected to. The presence of these capacitors must be considered during the electrical study prior to the start-up.
- Note: If particular aspects of an actual installation do not conform to the conditions described above, or if there are other conditions which should be considered, always contact your local Carrier representative.**
- (1) The required protection level for this class is IP43BW (according to reference document IEC 60529). All 30RBM/30RBP units are IP44CW and fulfil this protection condition.
  - (2) The maximum ambient temperature allowed for machines equipped with option 231 is +40°C.
  - (3) - Example of first environment installations: commercial and residential buildings.  
- Example of second environment installations: industrial zones, technical rooms powered from a dedicated transformer.

# DIMENSIONS/CLEARANCES

## 30RBM/30RBP 160-260 (with/without hydraulic module)

### Without hydraulic module

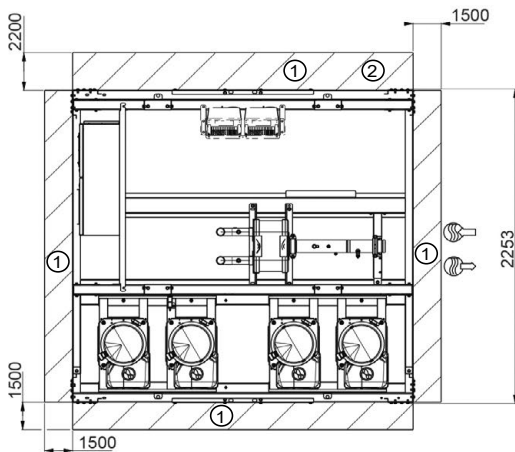
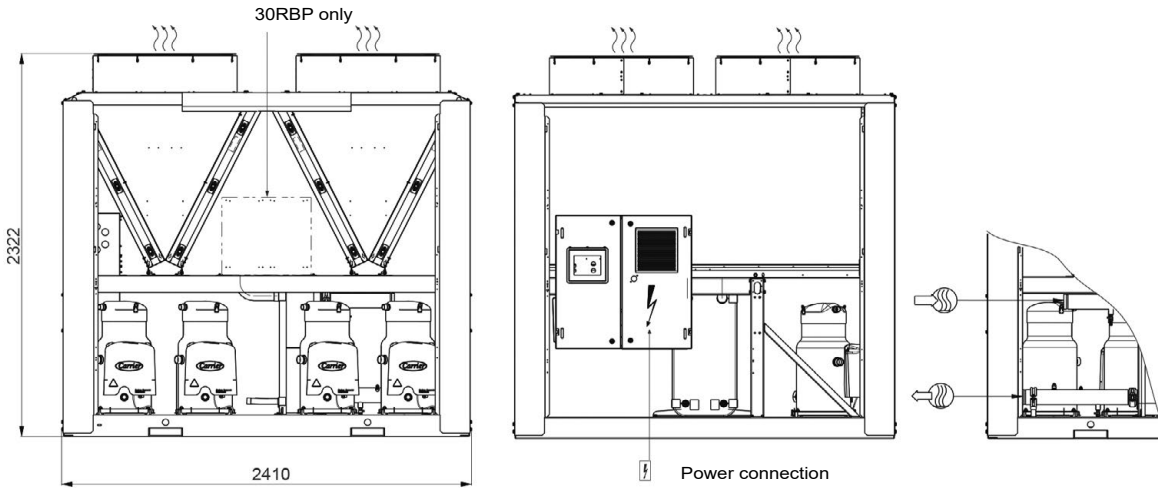

**Key:**

All dimensions are in mm.

- ① Clearances required for maintenance and air flow
- ② Clearance recommended for coil removal
- Water inlet
- Water outlet
- Air outlet, do not obstruct
- Electrical cabinet

**Note:** Drawings are not contractually binding. Before designing an installation, consult the certified dimensional drawings, available on request.

For the location of fixing points, weight distribution and coordinates of the centre of gravity, refer to the certified dimensional drawings.

### With hydraulic module

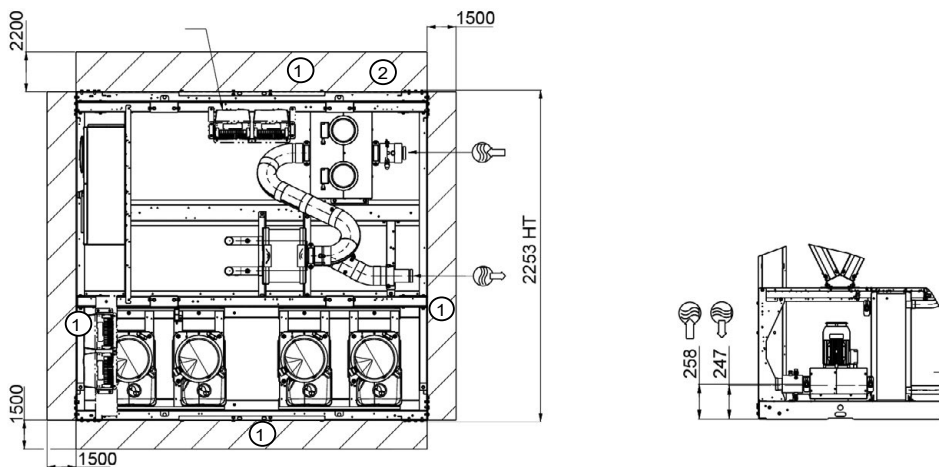

# DIMENSIONS/CLEARANCES

## 30RBM/30RBP 300-400 (with and without hydraulic module)

### Without hydraulic module

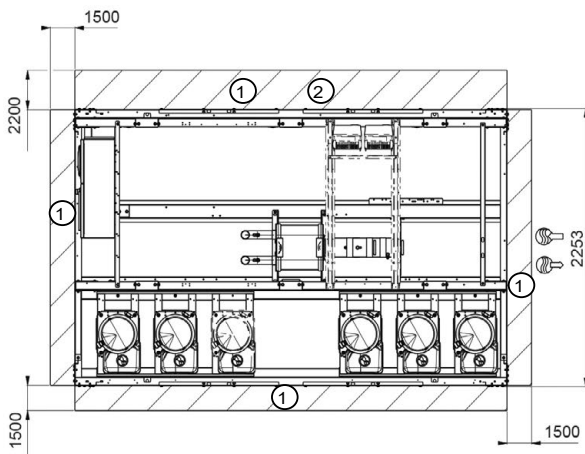
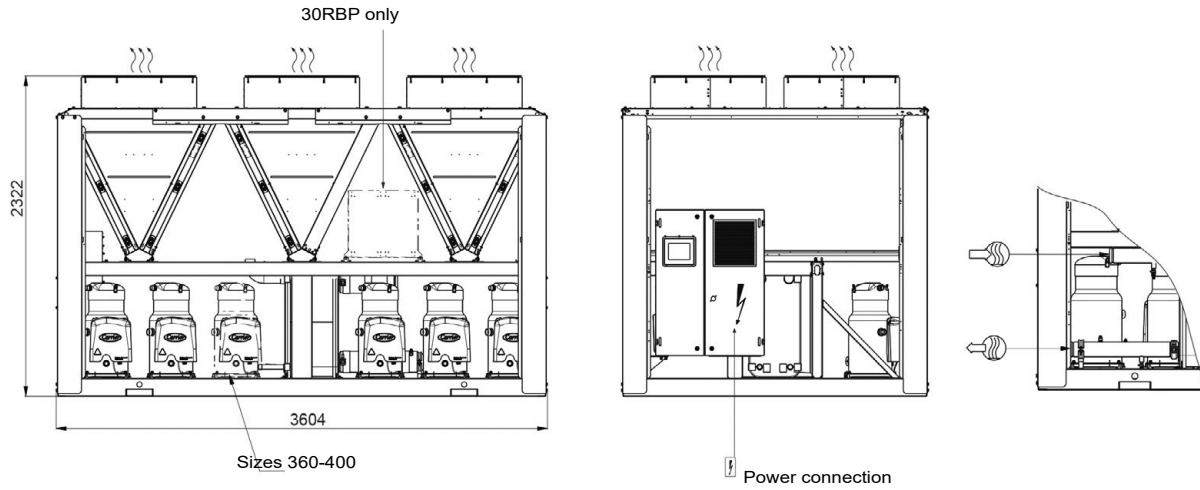

**Key:**

All dimensions are in mm.

- ① Clearances required for maintenance and air flow
- ② Clearance recommended for coil removal
- Water inlet
- Water outlet
- Air outlet, do not obstruct
- Electrical cabinet

**Note:** Drawings are not contractually binding. Before designing an installation, consult the certified dimensional drawings, available on request.

For the location of fixing points, weight distribution and coordinates of the centre of gravity, refer to the certified dimensional drawings.

### With hydraulic module

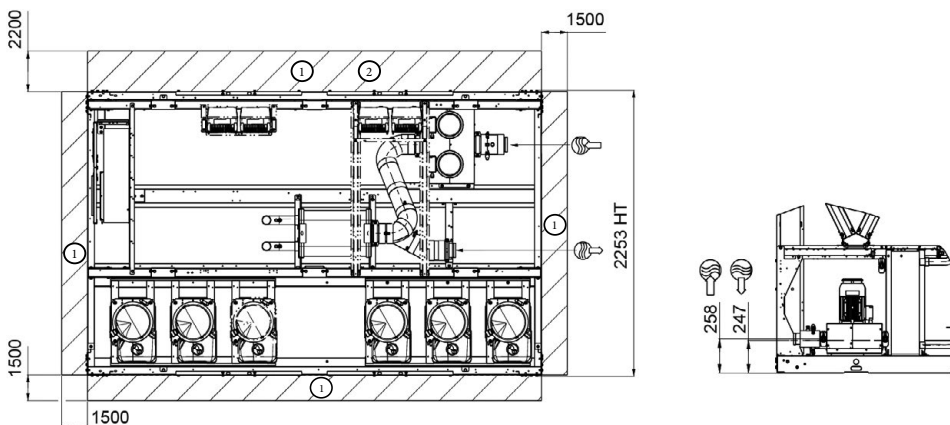

# DIMENSIONS/CLEARANCES

## 30RBP 430-520 (with and without hydraulic module)

### Without hydraulic module

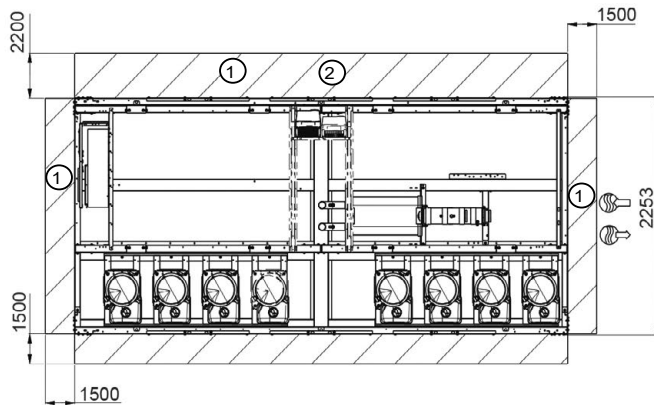
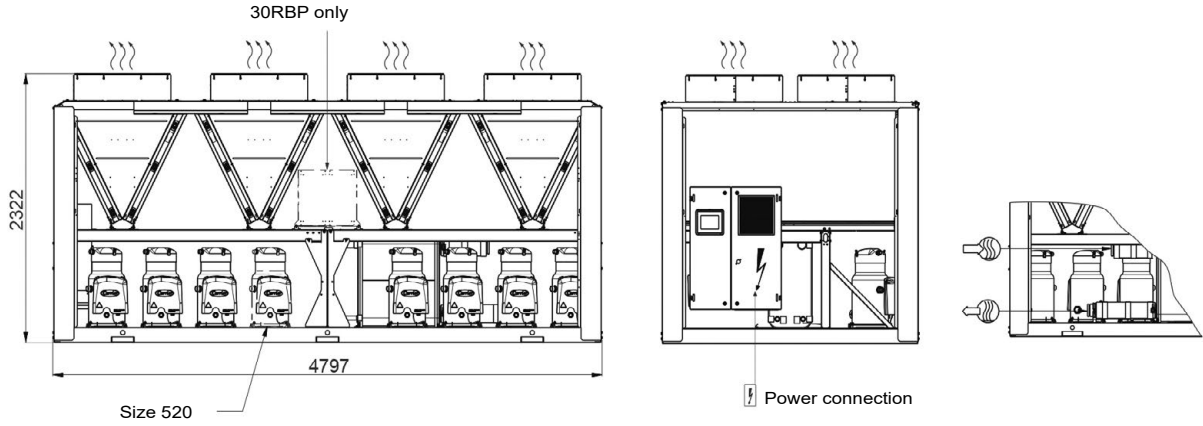

**Key:**

All dimensions are in mm.

- ① Clearances required for maintenance and air flow
- ② Clearance recommended for coil removal
- Water inlet
- Water outlet
- Air outlet, do not obstruct
- Electrical cabinet

**Note:** Drawings are not contractually binding. Before designing an installation, consult the certified dimensional drawings, available on request.

For the location of fixing points, weight distribution and coordinates of the centre of gravity, refer to the certified dimensional drawings.

### With hydraulic module

